

PG-8901578-8901582

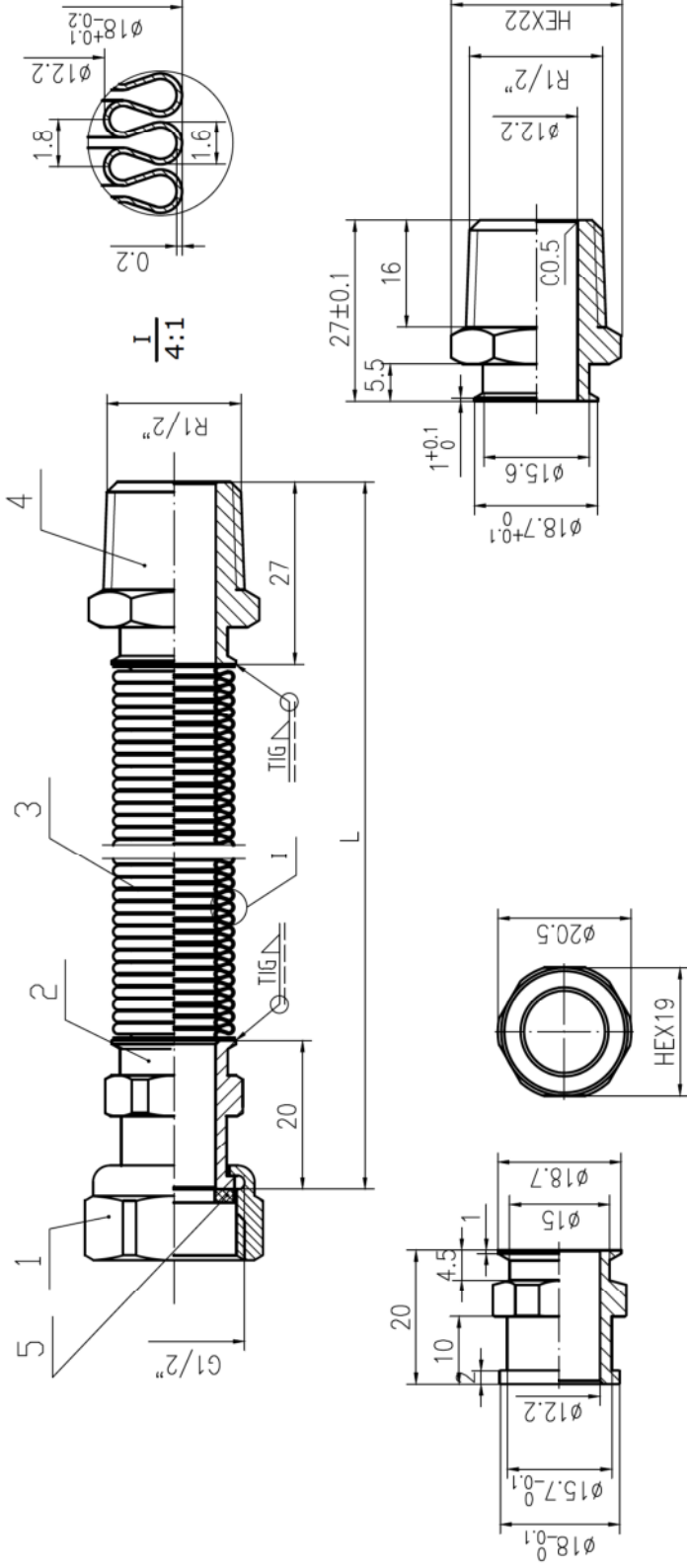

Technical requirement :

1. Annealing and compression
2. weld joint to be uniform
3. No scratches or other defects on the surface of the hose
4. Wave uniformity
5. Working pressure 3Bar
6. Working temperature: Max 110°C

5	TZX-401-15-01	Gaskets	2	EPDM		φ18.7xφ12x2.7
4	TZX-201-15-1	Male	1	ASTM304		
3	TZX-001-180-1	Metal hose	1	ASTM316L		φ18x0.2
2	TZX-308-15-1	Joint	1	ASTM304		
1	TZX-101-15-1	NUT	1	ASTM304		
No.	Code	Name	QTY.	Material	Remarks	
					weight	scale
						15:1
					Sheet	
					approved	
					1/2"MF	
					IPG-8901578-8901582	

CODE	8901578	8901579	8901580	8901581	8901582
L	75/130	110/210	200/410	260/520	500/1000