



KITS



PUMPEN



ZÄHLER



ZAPFVENTILZÄHLER



ZAPFVENTILE



ALTÖLAUSRÜSTUNG

# VISCOTROLL GEAR

## MERKMALE

- **BEDARFSABHÄNGIGE ABGABE**
- **EINSTELLBARER BYPASS**
- **GERÄUSCHARM**
- **SOFORT EINSATZBEREIT**
- **OVALRADZÄHLER**
- **WAGEN MIT ROBUSTER KONSTRUKTION**

Der PIUSI VISCOTROLL GEAR ist ein transportables Ölabgabemodul für die Beförderung von Schmiermitteln mittlerer/hocher Viskosität. Dieser vielseitige mobile Wagen ist in einer Wechsel- und Gleichstromausführung (AC bzw. DC) lieferbar (beide von einer PIUSI VISCOMAT Pumpe angetrieben).

### LEISTUNGSPARAMETER

BIS ZU

**9 L/MIN**

VOLUMENSTROM

UNTER

**65 DB**

GERÄUSCHPEGEL

**± 0,5%**

GENAUIGKEIT

BIS ZU

**2000 cSt**

VISSKOSITÄT



VISCOTROLL GEAR AC



VISCOTROLL GEAR DC



### VERPACKUNG

CODE	GEWICHT		VERPACKUNG			
	KG	LBS	MM	ZOLL	STCK./PALETTE	STCK./KARTON

#### VISCOTROLL DC 120/1

FOO263200	57	125,7	1090X690X320	42,9X27,2X11,8		1
FOO263210	58	125,9	1090X690X320	42,9X27,2X11,8		1

#### VISCOTROLL AC 200

FOO26300D	34	75	1090X690X300	42,9X27,2X11,8		1
FOO26301D	35	77	1090X690X300	42,9X27,2X11,8		1
FOO26302D	36	79,4	1090X690X300	42,9X27,2X11,8		1
FOO26303D	37	81,6	1090X690X300	42,9X27,2X11,8		1



FILTERUNG



ÖLÜBERWACHUNG



TANKÜBERWACHUNG



SCHLAUCHAUFROLLER



ZUBEHÖR



MERCHANDISE



LUFT



FROSTSCHUTZ



AdBlue®



BIODIESEL



DIESEL



LEBENS.M.



BENZIN



SCHMIERM.



KEROSIN



ÖL



WASSER



WISCHERFLÜSS.

## KENNLINIEN

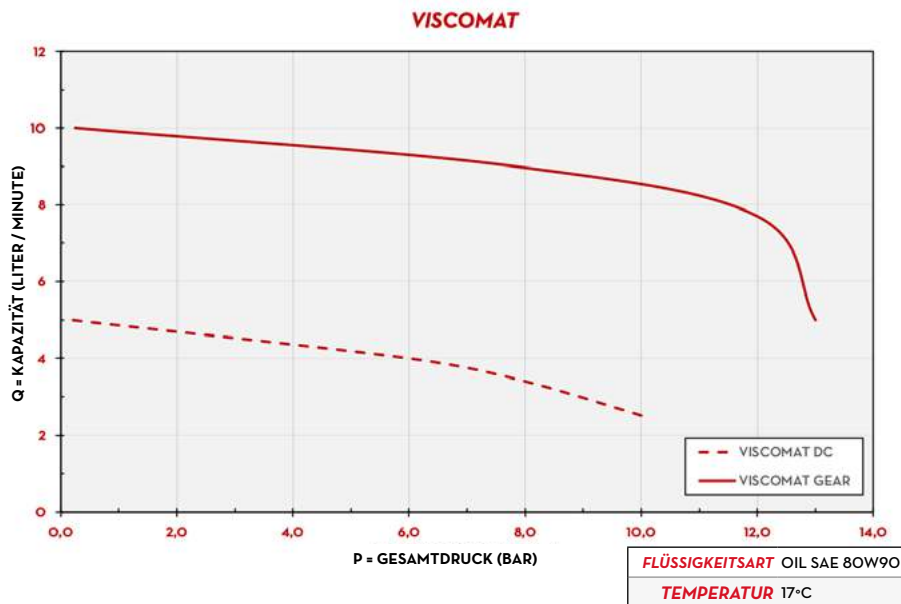

## LIEFERUMFANG

- VISCOMAT PUMPE
- INLINE-VENTIL
- ZAPFVENTIL EASY OIL / EASY K400
- BATTERIELADEGERÄT (NUR DC-GLEICHSTROMAUSFÜHRUNG)
- WAGEN
- FUSSVENTIL
- SCHUTZ DER DREHKUPPLUNG
- BEDIENUNGSANLEITUNG

## EINZELHEITEN



ZAHNRADPUMPE



DRUCKSCHALTER



BATTERIELADEGERÄT

## ABMESSUNGEN

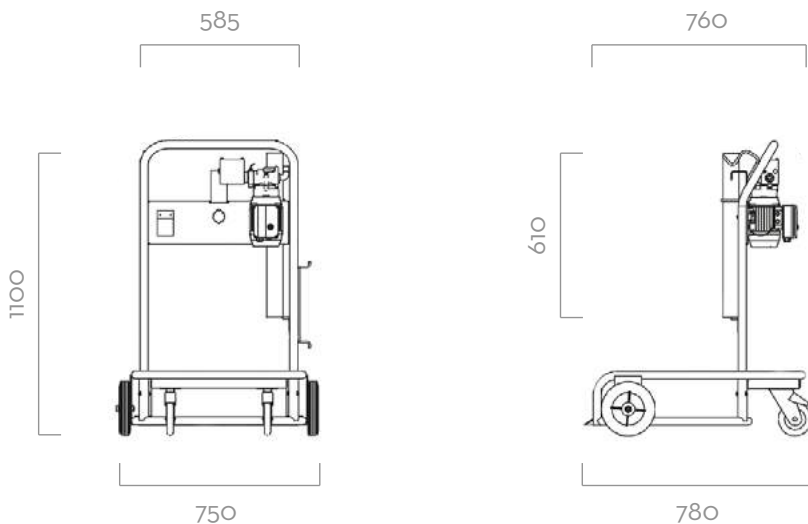

## KOMPONENTEN

- **PUMPE:**  
 VISCOMAT GEAR S. 34  
 VISCOMAT DC S. 38  
 VISCO FLOWMAT S. 36
- **ZAPFVENTILZÄHLER:**  
 EASY K400 S. 88
- **ZAPFVENTIL:**  
 EASY OIL S. 104

## TECHNISCHE DATEN

CODE	BESCHREIBUNG	FLÜSSIGKEITSART	VOLUMENSTROM		VISKOSITÄT CST MAX.	SPANNUNG			ZÄHLER MOD.	PUMPE MOD.	ZAPFVENTIL TYPE	DRUCKSCHALTER	BATTERIELADEGERÄT VOLTIOS
			L/MIN	GPM		AC V./HZ DC V.	POWER WATT	AMP. MAX.					
<b>VISCOTROLL DC 120/1</b>													
FO0263200	VISCOTROLL 120/1 DC PST.	⊙	6	1,6	2000	12	360	30	-	VISCOMAT 120/1 DC	EASY OIL	JA	230
FO0263210	VISCOTROLL 120/1 DC PST.K 400	⊙	6	1,6	2000	12	360	30	K400	VISCOMAT 120/1 DC	EASY K400	JA	230
<b>VISCOTROLL AC 200</b>													
FO026300D	VISCOTROLL 200/2 AC	⊙	9	2,4	2000	230/50	800	3,8	-	VISCOMAT GEAR 200/2	EASY OIL	NEIN	-
FO026301D	VISCOTROLL 200/2 AC - K400	⊙	9	2,4	2000	230/50	800	3,8	K400	VISCOMAT GEAR 200/2	EASY K400	NEIN	-
FO026302D	VISCOTROLL 200/2 AC - PST	⊙	9	2,4	2000	230/50	800	3,8	-	VISCO-FLOWMAT 200/2	EASY OIL	JA	-
FO026303D	VISCOTROLL 200/2 AC - PST - K400	⊙	9	2,4	2000	230/50	800	3,8	K400	VISCO-FLOWMAT 200/2	EASY K400	JA	-

# VISCOTROLL GEAR