

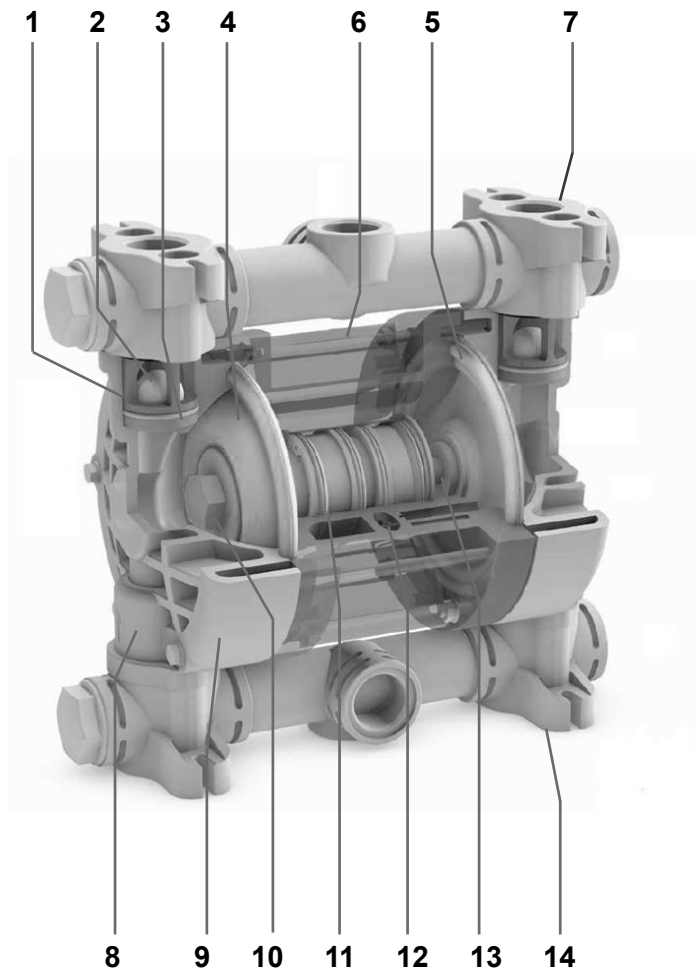

PIUSI s.p.a. - Via Pacinotti, 16/A - 46029 Suzzara (MN) ITALY
Tel. (+39) 0376/534 561 - fax (+39) 0376/536 393 - www.piusi.com

PIUSI

IDENTIFICATION AND NOMENCLATURE OF PARTS

POS.	NOMENCLATURE	POS.	NOMENCLATURE
1	PRODUCT DELIVERY VALVES	8	PRODUCT SUCTION VALVES
2	BALL VALVE	9	PUMP CASING
3	BALL VALVE SEAT	10	CAP
4	OUTER DIAPHRAGM (PRODUCT SIDE)	11	PNEUMATIC EXCHANGER
5	INNER DIAPHRAGM (AIR SIDE)	12	AIR SUPPLY CONNECTION
6	CENTRAL	13	SHAFT
7	DELIVERY MANIFOLD	14	SUCTION MANIFOLD

All rights of total or partial reproduction, translation and adaptation by any means are reserved in all countries.

INDEX

CHAPTER 1	GUIDANCE DOCUMENTS	4
1.1	DECLARATION OF CONFORMITY	5
1.2	LIST OF RESIDUAL RISKS	6
1.3	INTRODUCTION	7
1.4	FOREWORD	11
1.5	GENERAL NOTES ON DELIVERY	11
1.6	WARRANTY	12
CHAPTER 2	INTRODUCTORY INFORMATION	13
2.1	PUMP IDENTIFICATION	14
2.2	ATEX MARKING AND DEFINITION	15
2.3	PUMP DESCRIPTION	17
2.4	INTENDED USE AND IMPROPER USES	17
2.5	TECHNICAL FEATURES	18
CHAPTER 3	WARNINGS AND REQUIREMENTS	20
3.1	SAFETY RULES	21
CHAPTER 4	TRANSPORT AND POSITIONING	25
4.1	STORAGE AND PRESERVATION	26
4.2	TRANSPORT AND HANDLING	27
4.3	POSITIONING AND INSTALLATION	28
4.4	PNEUMATIC CONNECTION	31
4.5	CHECKS PRIOR TO COMMISSIONING	33
CHAPTER 5	COMMISSIONING AND STOP	34
5.1	COMMISSIONING AND OPERATION	35
5.2	NORMAL STOP OF THE PUMP	37
5.3	EMERGENCY STOP OF THE PUMP	38
CHAPTER 6	ROUTINE MAINTENANCE	39
6.1	SCHEDULED MAINTENANCE TABLE	40
6.2	EXTERNAL CLEANING AND TIGHTNESS CHECK	41
6.3	TIGHTNESS CHECK	43
6.4	PRODUCT CIRCUIT MAINTENANCE	45
6.5	AIR CIRCUIT maintenance	50
CHAPTER 7	TROUBLESHOOTING	53
CHAPTER 8	DECOMMISSIONING AND DISPOSAL	55
8.1	DECOMMISSIONING AND WASHING FORM	56
8.2	DISPOSAL	58

CHAPTER 1

This chapter includes the Declaration of Incorporation, the List of Residual Risks and information on the structure of the Translation of Original Instructions so that Operators and Technicians can properly consult the manual itself.

THIS PART INCLUDES THE FOLLOWING TITLES		PAGE
1.1	DECLARATION OF CONFORMITY	5
1.2	LIST OF RESIDUAL RISKS	6
1.3	INTRODUCTION	7
1.4	FOREWORD	11
1.5	GENERAL NOTES ON DELIVERY	11
1.6	WARRANTY	12

Below is a detailed description of each topic mentioned.

1.1 DECLARATION OF CONFORMITY

EU DECLARATION OF CONFORMITY (2014/34/EU, AII. X)

The manufacturer: PIUSI S.p.A.
Via Pacinotti, 16/A - z.i. Rangavino
46029 Suzzara (MN) Italy

Declares under its own and sole responsibility that the machine:

Type: **PNEUMATIC DOUBLE DIAPHRAGM PUMP**

Model: **PIUSI MA 130, PIUSI MA 180, PIUSI MA 190, PIUSI MP 130, PIUSI MA 140,
PIUSI MP 140, PIUSI MP 180, PIUSI MP 190**

Year of manufacture: refer to the year of production shown on the CE plate affixed to the product.

Comply with all relevant provisions of the following directives:

- 2014/34/EU

and the following harmonized standards, applied standards and/or technical specifications:

EN ISO 80079-36:2016 EN ISO 80079-37:2016 EN ISO 80079-38:2016

This equipment is classified as follows:

 **II 3G Ex h IIB T4 Gc**

 **II 3D Ex h IIIB T135°C Dc X**

Read the Use and Maintenance manual before using the pump.

Place: Suzzara (MN)

Date: 01/09/2023



Otto Varini
Legal Representative

1.2 LIST OF RESIDUAL RISKS



After a careful analysis and assessment of the hazards present during the operational phases affected by the MA-MP series Pneumatic Pumps, the necessary measures were taken to eliminate or reduce the associated risks and the residual risks were reported and dealt with in the Installation, Use and Maintenance Manual (Original Instructions) provided with the pump, so that they can be further reduced or eliminated through the design and integration of safety of the machines in which they will be installed:

HANDLING AND POSITIONING - CONSULT PROCEDURES IN THE ORIGINAL INSTRUCTIONS

- Impact and crushing hazard

INSTALLATION - CONSULT PROCEDURES IN THE ORIGINAL INSTRUCTIONS

- Hazards related to toxic and/or corrosive liquids to be pumped;
- Danger of chemical incompatibility with the fluids to be pumped;
- Danger of produced leakage with dangerous fluids; (provide flow and collection containment protections);
- Danger of chemical reaction with fluids reacting to tap water for testing; (open and dry the internal parts of the pump before installing it);
- Crushing hazard.

OPERATION - CONSULT PROCEDURES IN THE ORIGINAL INSTRUCTIONS

- Hazards related to toxic and/or corrosive liquids to be pumped;
- Danger of chemical incompatibility with the fluids to be pumped;
- Danger of stress corrosion cracking (combined action of corrosion and/or incorrect application of a load) combined with high temperatures;
- Fire hazard due to the deposit of flammable dust or use with temperatures higher than those shown on the product Identification Plate.

CLEANING AND MAINTENANCE - CONSULT PROCEDURES IN THE ORIGINAL INSTRUCTIONS

- Hazards related to toxic and/or corrosive liquids to be pumped;
- Danger of projection of pump parts during disassembly, due to residual internal pressures (anomalous) in the pneumatic circuit of the pump;
- Danger of rupture of diaphragms in the absence of Scheduled Maintenance.

Those designing the machine/system in which the MA-MP series Pneumatic Pump will be installed must consider the residual risk indicated in each operational phase and must take the necessary safety integration measures provided by the applicable directives, before commissioning. **It is forbidden to commission the pump before the Machine in which it will be incorporated has been declared compliant with Directive 2006/42/EC and any further applicable specific Regulations and/or Directives.**

Whoever works in these areas and deals with these operational phases must be a trained person and aware that there may still be "residual risks" (related to the type of fluid used and the chemical compatibility) that it was not possible to eliminate.

Those in charge of these operations must always have at their disposal (consult and understand) all the information contained in the Manufacturer's Manual (Original Instructions or Translation of Original Instructions) and must obtain the necessary Personal Protective Equipment (PPE) provided, before intervening.

The Customer, the Installation and Maintenance Technicians, the Qualified Operators are responsible for arranging all the necessary measures so that access near the pump is reserved and limited to trained and qualified personnel and providing adequate information and reports of any residual risk on the machine/system in which it will be installed, in compliance with current safety laws.

Since an endless variety of products and chemical compositions of the fluids exists, the user is presumed to have the best knowledge of their compatibility and chemical reaction with the pump's construction materials. **The purchaser is strictly responsible for selecting the construction materials compatible with the fluid(s) with which the pump components come into contact.** The user can contact the Manufacturer or the Distributor for suggestions in relation to the construction materials that offer the best chemical compatibility, however, neither the Manufacturer nor the Distributor will be held liable for damage (malfunction, structural ageing, leakage or indirect damage) attributable to chemical incompatibility reactions between the pump materials and the fluids that come into contact with them.

1.3 INTRODUCTION



The Original Instructions have been developed taking into account all sizes and the different supply configurations of the MA-MP series Pneumatic Pumps, and the steps necessary for correct installation and safe use.

This manual is an integral part of the pump and represents a safety device with which the Manufacturer intends to provide important information so that the Purchaser and his/her personnel can install, use and maintain it constantly efficient and safe.

The processed information is aimed at pursuing the highest level of safety for the environment, the exposed people and the technicians qualified for the operations foreseen by the Manufacturer.

CONSULTATION AND PRESERVATION

The Manufacturer's Original Instructions must be kept in good condition and must always be available for consultation by the Technicians qualified to intervene on the machine in which it will be installed.

On the contrary, the Manufacturer is relieved of any liability with regard to:

- Incorrect installation;
- Incorrect or missing assessments of chemical compatibility with the fluid to be pumped;
- Incorrect or missing assessments of classification of the potentially explosive environment and of suitability for pump use according to the affixed Certification marking and the Declaration of Conformity;
- Improper use of the pump and/or for performances other than those declared;
- Use with higher temperatures than those declared by the Manufacturer;
- Interventions and/or use of the same by untrained personnel;
- Use contrary to the Manufacturer's safety rules;
- Serious deficiencies in maintenance;
- Changes or interventions not authorised by the Manufacturer;
- Use of non-original spare parts and/or unsuitable parts for the pump;
- Total or partial non-compliance with the Manufacturer's Original Instructions.

RECIPIENTS OF THE ORIGINAL INSTRUCTIONS

This Original Instructions manual is addressed to all Operators and Technicians qualified to transport, handle, install and maintain and/or repair the pump.

All Operators and qualified Technicians who interact with and intervene on the pump must be aware of the intervention procedures established by the Manufacturer, of the residual risk present and of the safety measures that must be adopted to prevent dangerous situations, and any damage that may arise for exposed people, operators, for the environment and for property in general. In particular, Operators must be aware of all personal protective equipment to be used during interventions that require working near potentially dangerous areas.

The contents of this manual must be strictly followed.

LIMITS OF THE ORIGINAL INSTRUCTIONS

Please note that the instruction manual cannot replace the adequate knowledge and technical preparation of the installer or maintenance technician. This Manual provides information and instructions on installation and maintenance that do not intend to replace or modify any general or specific standard, requirement or law concerning safety and use, which affects the machine on which the pump will be installed.

UPDATES TO THE ORIGINAL INSTRUCTIONS

The manual reflects the state-of-the-art and technique at the time of marketing the pump and cannot be considered inadequate only because it is not updated on the basis of any and future technical achievements.

The Manufacturer reserves the rights to update production and the manual without prior notice, and without obligation to update the previously issued documents.

CONTENTS OF THE ORIGINAL INSTRUCTIONS

The topics are covered in order to allow a classification of the information and the professional address to which they are addressed, so that the contained information can be immediately and directly consulted.

The manual is divided into chapters and related sections that deal with the operational topics for correct installation, use and maintenance of the pump, with exposure divided into numbered sequences.

The pages are characterised by the following structure and contents:

- A bar has been created at the beginning of each section which, through symbols, indicates the personnel authorised to perform the operation, the prohibitions to be observed, the obligations and the Personal Protective Equipment (PPE) that must be used;
- The residual risk that may occur during the operations is highlighted by appropriate symbols, integrated with the text.

Authorised Personnel

Operational Sequences

Title SECTION

CAUTIONS WARNINGS and NOTES

Title CHAPTER

Contents Graphs

Numbers PAGE

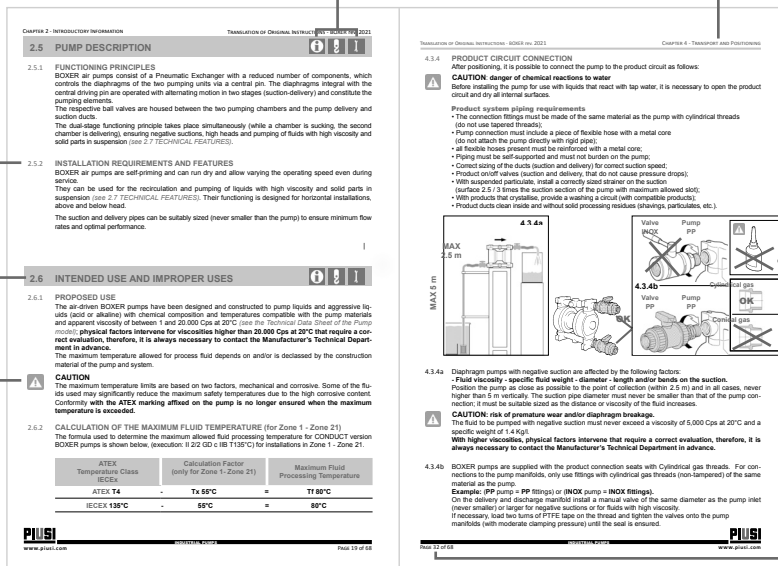

Special symbols are used within the manual to highlight and differentiate particular information or suggestions important for the safety and/or correct installation, maintenance or replacement of the pump.

With these precautions, the Manufacturer intends to draw the attention of qualified Technicians to the CAUTIONS, WARNINGS or NOTES concerning them.

For any doubts or clarifications regarding the contents of this manual, do not hesitate to contact the Manufacturer's Technical Service.

Tel. +39 0376 534 561
 Fax +39 0376 536 393
 e-mail: customercare@piusi.com
 website: www.piusi.com

SYMBOLS AND DEFINITIONS



MACHINE OPERATOR

Identifies the type of Operator to whom the mentioned intervention is reserved. This qualification requires having obtained the necessary training and specific skills in the field of use of the pump, in addition to full knowledge and understanding of the information contained in the Manufacturer's user manual.



HANDLING OPERATOR

Identifies the type of Operator to whom the mentioned intervention is reserved. This qualification requires specific skills for lifting equipment, safe methods and characteristics for slinging and handling as well as a full knowledge and understanding of the information contained in the Manufacturer's user manual.



INSTALLER/MECHANICAL SERVICEMAN

Identifies the type of Technician to whom the mentioned operation is reserved. This qualification requires having obtained the necessary training and specific skills to carry out installation and maintenance and full knowledge and understanding of the information contained in the Manufacturer's user manual.

EXTRAORDINARY PROCEDURES



Identifies the operations that can only be performed by the Manufacturer's After-Sales Service Technicians.

HAZARD SYMBOLS

They indicate, together with the text, the type of residual risk that may occur during the mentioned operation:



General danger.



Temperature hazard.



Danger of toxic and/or corrosive fluids.



Explosion hazard.



Danger of crushing and sectioning.

PROHIBITION SYMBOLS

They indicate, together with the text, the type of prohibition to be observed during the mentioned operation:



Prohibition to come into contact with component parts when it is powered, running or hot.



Prohibition to remove the guards with the pump powered or running.



Prohibition to lubricate.

SYMBOLS AND DEFINITIONS

MANDATORY SYMBOLS

They indicate, together with the text, the type of personal protection to be obtained to carry out a certain operation:



Obligation to disconnect the power supply before intervening.



Obligation to wear gloves with toxic and corrosive fluids.



Obligation to wear protective and anti-slip shoes.



Obligation to wear aprons with toxic and corrosive fluids.



Obligation to wear a face mask with toxic and corrosive fluids.



Obligation to wear a respirator with toxic and corrosive fluids.



CAUTION

It informs the personnel concerned that the described operation involves a residual risk of exposure to dangers with possible harm to health, personal injuries and/or environmental damage, if not carried out in compliance with the requirements and procedures described and/or in the absence of the required suitable Personal Protective Equipment (PPE).



WARNING

It informs the personnel concerned that the described operation may cause damage to the pump, and/or its components and consequent risks for the Operator, Technicians and/or for the environment if not carried out in compliance with the prescribed procedures.



NOTE

It provides significant technical details relating to the topic and/or operation in question, the content of which is of technical importance or of a technical/legal nature.

1.4 FOREWORD



MA-MP pumps have been manufactured in accordance with Directives 2006/42/EC and 2014/34/EU in compliance with the harmonised European standards EN ISO 80079-36:2016, EN ISO 80079-37:2016 and EN ISO 80079-38:2016.

With the drafting of this manual, the Manufacturer hopes that you can make the most of the performance of the MA-MP pumps, in complete safety; the MA-MP pumps do not represent any risk to operators if used in compliance with the Manufacturer's Original Instructions.

The Customer, the Installation and Maintenance Technicians and the Qualified Operators are responsible for arranging the necessary measures so that access near the pump is reserved to trained and qualified personnel and providing adequate information and reports of any residual risk on the machine or system in which it will be installed, in compliance with current safety laws.

All technical values refer to the "standard" MA-MP pumps (*see 2.7 TECHNICAL FEATURES*) and we remind you that due to a constant search for innovation and technological quality, the technical features of the products could change without prior notice; **it is necessary to always follow the version of the Original Instructions provided with the pump.**

It is forbidden to commission the pump, before the Machine in which it will be incorporated has been declared compliant with the provisions of Machinery Directive 2006/42/EC, as well as with any further other applicable Regulations and/or Directives.

Please note that the Original Instructions Manual, the Drawings and any other Technical Document delivered with the pump are confidential and the property of the Manufacturer who reserves all rights (intellectual property) and PROHIBITS the reproduction (even partial with any means) and the disclosure to third parties without its written approval.

1.5 GENERAL NOTES ON DELIVERY



Upon receipt of the supply, check that:

- the packaging is intact
- the supply corresponds to the order specifications (see accompanying document)
- the pump has not been damaged.

DESCRIPTION OF THE SUPPLY	POS.
Pump	1
Official Manual (Original Instructions)	2

In the event of actual damage, or missing parts, immediately inform (within 7 days of receipt) and in detail (possibly with photographs) the Manufacturer and the Carrier.

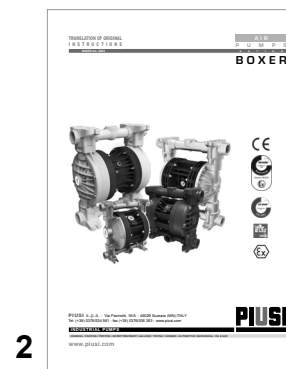
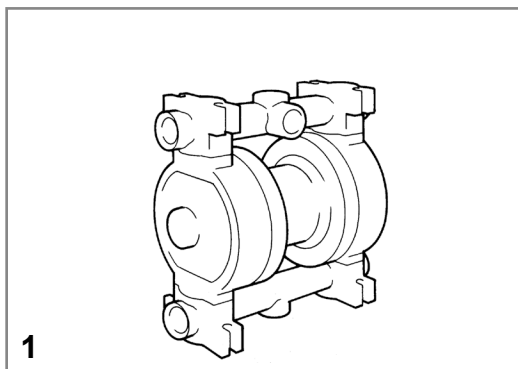

1.6 WARRANTY



The high quality of MA-MP pumps is promptly confirmed to us by our Customers' satisfaction. However, should any defect appear, please contact the Manufacturer's After-Sales Service, your Dealer or the nearest Customer Service Centre where you will receive assistance as quickly as possible.

In any case, provide the following:

- A. Identification of the pump through the Serial number on the label affixed to it;
- B. Description of the detected anomaly.

All MA-MP pumps are covered by the following warranty:

1 WARRANTY TERMS

The pump is warranted on all mechanical parts found to be defective, except for the parts subject to normal wear due to operation.

For the warranty period, refer to the seller's warranty conditions

The warranty provides for the free repair of the pump or the supply in replacement of the defective parts, provided that the Manufacturer acknowledges the manufacturing defect.

The repair or replacement of defective parts constitutes full satisfaction of the warranty obligations.

2 INTERVENTION NOTIFICATION

The Purchaser must report any defect to the Manufacturer in writing within 8 days.

3 METHODS OF INTERVENTION

The warranty intervention will be exclusively carried out at the Manufacturer's workshop after shipment or sending of the defective pump at the Purchaser's expense.

4 EVALUATION RESERVE

Warranty shall not be extended in case of repair or replacement.

5 EVALUATION RESERVE

The defective parts remain the Manufacturer's property the moment they are replaced by the same under warranty. If the parts are found not to be defective, the Manufacturer reserves the right to invoice the full cost of the parts that have been replaced under warranty.

Purchaser responsibility

The Manufacturer will not bear the costs and risks for the shipping or transport of the defective and/or repaired or replaced parts, including any custom charges. The warranty DOES NOT cover any indirect damage and, in particular, any lack of production. In addition, the warranty does not cover any normal consumable materials (diaphragms, balls and ball seats, etc.). The warranty does not cover parts damaged as a consequence of incorrect installation, carelessness, neglect, incorrect maintenance, or damages due to transportation or to any other reason or event that is not directly linked to functional or manufacturing defects.

Warranty and liability exclusion for chemical reactions:

Since an endless variety of products and chemical compositions of the fluids exists, the user is presumed to have the best knowledge of their compatibility and chemical reaction with the pump's construction materials. **The purchaser is strictly responsible for selecting the construction materials compatible with the fluid(s) with which the pump components come into contact.** The user can contact the Manufacturer or the Distributor for suggestions in relation to the construction materials that offer the best chemical compatibility, however, neither the Manufacturer nor the Distributor will be held liable for damage (malfunction, structural ageing, leakage or indirect damage) attributable to reactions due to chemical incompatibility between the pump materials and the fluids that come into contact with them.

The warranty excludes all cases of tampering, improper use or incorrect applications or non-observance of the information contained in the Manufacturer's Original instruction manual.

Any controversy falls within the jurisdiction of the Court of ITALY.

This chapter of the manual deals with topics of a preliminary nature but very important for the safe and correct use of the pump; therefore, follow the instructions in the sections below.

THIS PART INCLUDES THE FOLLOWING TITLES		PAGE
2.1	PUMP IDENTIFICATION	14
2.2	ATEX MARKING AND DEFINITION	15
2.3	PUMP DESCRIPTION	17
2.4	INTENDED USE AND IMPROPER USES	17
2.5	TECHNICAL FEATURES	18

Below is a detailed description of each topic mentioned.

2.1 PUMP IDENTIFICATION



- 2.1.1 For any communication with the Manufacturer or authorised After-Sales Centers, always specify the data shown on the identification plate of the pump.

The identification plate contains the following data:

1. Manufacturer's Identification;
2. Manufacturer's address and contact numbers;
3. Pump name;
4. **Code of the pump;**
5. **ATEX Marking;**
6. Identification code (serial number);
7. Year of manufacture:

ATEX: STANDARD - CONDUCT version

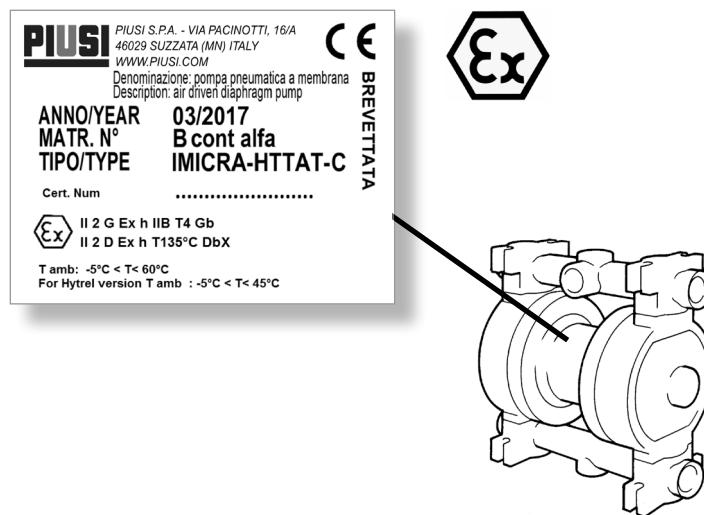

CAUTION

The Identification Plate and the Declaration of Conformity contain very important data. The shown data indicate the ATEX execution class (*see ATEX Marking marking*) for the correct assessment of compatibility with the workplace. **IT IS FORBIDDEN to remove and/or alter the identification plate and the data it contains; removal involves forfeiture of the warranty.**

- 2.1.2 The number of this manual is written on the cover. Make a note of the revision code and keep it so that, in case of loss, you can request a new copy.

2.2 ATEX MARKING AND DEFINITION



All MA-MP Air Pumps comply with the Community Directives for the free circulation of goods applicable to them (see *Declaration of Conformity*).

They are manufactured in STANDARD version in ATEX **Ex II 3G Ex h IIB T4 Gc** and **Ex II 3D Ex h IIIB T135°C DcX** execution for use in “Zone 2-Zone 22” (in the presence of flammable gas and powders)

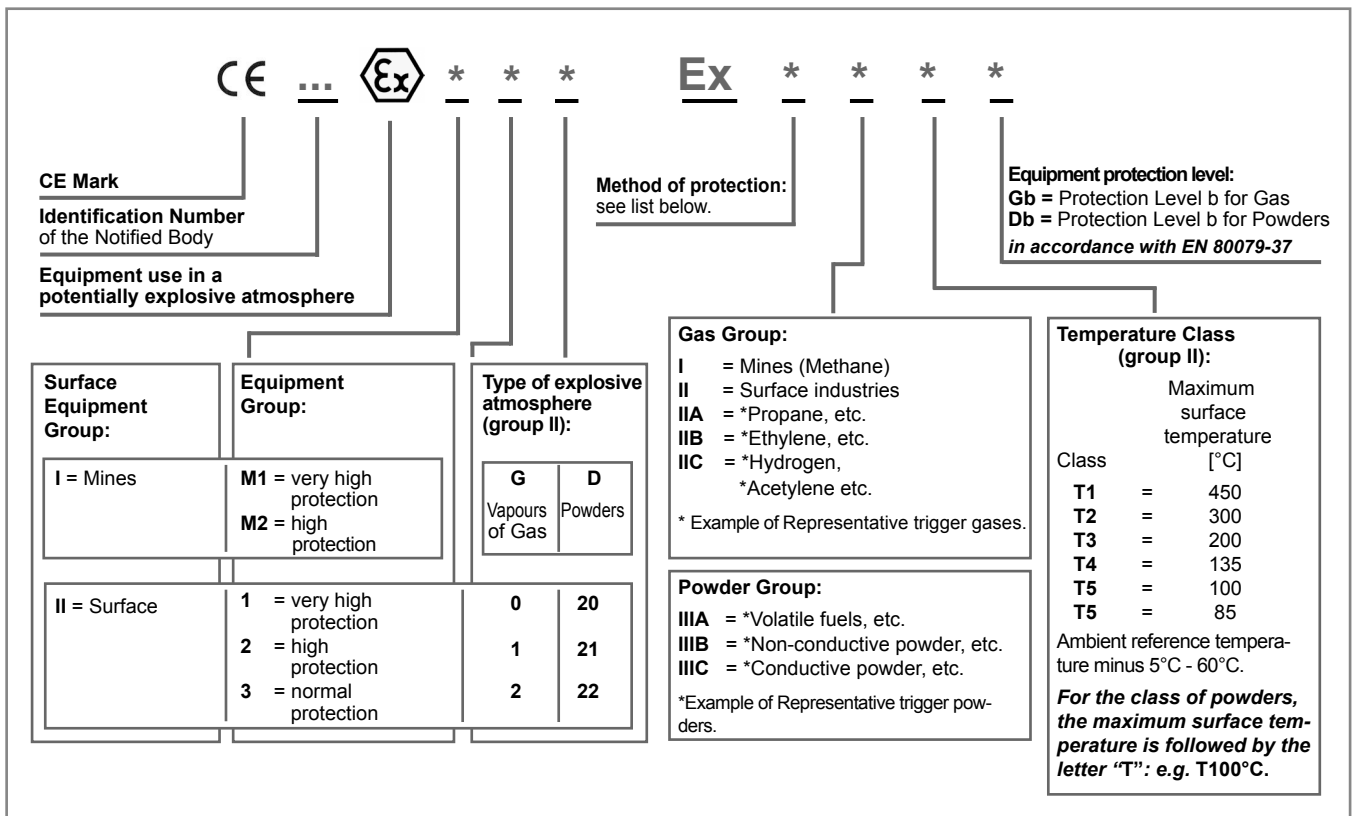

CAUTION

The Identification Plate of the pump shows the ATEX marking and the category of the equipment. **Check compliance with the classification of the installation “Zone” before carrying out the installation. The equipment user is responsible for classifying their installation zone.** Below is the definition of the ATEX marking of each execution.



: safety symbol in accordance with DIN 40012 attachment A.

II 3G/II 3D: surface equipment for use in areas where the presence of gases, vapours or mists in addition to clouds of combustible powder in the air is unlikely during normal operation, both in external and internal areas and, if it does occur, it will only persist for a short period (Zone 2 - Zone 22).

II 2G/II 2D: surface equipment for use in areas with the presence of gases, vapours or mists in addition to clouds of combustible dust in the air that occur occasionally during normal operation, both in external and internal areas (Zone 1 - Zone 21).

IM2: category M2 equipment that can be installed in mines in “hazardous condition 2” or in potentially explosive atmosphere consisting of firedamp and coal dust.



- Ex h** : Protection equipment «c», or «b», or «k», in accordance with EN 80079-37.
- IIB** : excluding the following gases: hydrogen, acetylene, carbon disulphide.
- IIIB** : excluding the following powders: conductive powder.
- I** : product suitable for installation in mines (in a low impact risk area).
- MB** : EPL Mb protection level in accordance with EN 80079-36:16.
- X** : The internal area of the pump is not ATEX, that is, it cannot process powders.
- T4/T135°C** : class of admitted temperatures. The processed fluid temperature value must fall within such class range and the user must comply with the instructions contained in the manual and with the current laws. Furthermore, the user must take into account the ignition point of the gases, vapours and mists in addition to clouds of combustible powder in the air existing in the area of use.

2.3 PUMP DESCRIPTION



2.3.1 FUNCTIONING PRINCIPLES

MA-MP air pumps consist of a Pneumatic Exchanger with a reduced number of components, which controls the diaphragms of the two pumping units via a central pin. The diaphragms integral with the central driving pin are operated with alternating motion in two stages (suction-delivery) and constitute the pumping elements.

The respective ball valves are housed between the two pumping chambers and the pump delivery and suction ducts.

The dual-stage functioning principle takes place simultaneously (while a chamber is sucking, the second chamber is delivering), ensuring negative suctions, high heads and pumping of fluids with high viscosity and solid parts in suspension (see 2.7 TECHNICAL FEATURES).

2.3.2 INSTALLATION REQUIREMENTS AND FEATURES

MA-MP air pumps are self-priming and can run dry and allow varying the operating speed even during service.

Their functioning is designed for horizontal installations, above and below head.

The suction and delivery pipes can be suitably sized (never smaller than the pump) to ensure minimum flow rates and optimal performance.

2.4 INTENDED USE AND IMPROPER USES



2.4.1 PROPOSED USE

The air-driven MA-MP pumps have been designed and constructed to pump:
 Piusi MP water, windscreen, antifreeze, DEF
 Piusi MA oil, waste oil, diesel fluid

2.4.2 IMPROPER USES

Any use of a MA-MP pump other than that previously described and specified in Section 2.7 TECHNICAL FEATURES, is to be considered improper and is therefore forbidden by PIUSI.

In particular, it is FORBIDDEN to use MA-MP pumps for:

- production of vacuum;
- operation as an on-off valve, as a check valve (non return valve) or as a metering valve;
- pump operation for pumping powders of all types and kinds (flammable and non);
- use with fluids to be pumped other than those explicitly foreseen
- operation with air pressures, process temperatures and/or functional characteristics that are incompatible with the Technical Data of the pump and/or the Certification marking affixed;
- pump operation in potentially explosive environments that are not classified and/or compatible with the type of execution of the pump (see Certification marking affixed and Declaration of Conformity).
- unsuitable pump use (incorrect choice of materials and installations) to operate in the presence of stress corrosion cracking phenomena;
- operation with alimentary or pharmaceutical fluids.



CAUTION

The risks associated with use of the pumps under the exact conditions set forth in the Manufacturer's use and maintenance manual have been analysed, whilst the analysis of the risks associated with the interface with other system components must be carried out by the installer/user.

Use of the pump that does not comply with the Manufacturer's Original Instructions is prohibited and invalidates the Warranty, the safety and explosion protection requirements.

2.5 TECHNICAL FEATURES



The performance technical data of the MA-MP pumps refer to standard versions. The “MAX Delivery” values refer to pumping of water at 20°C, with an immersed suction pipe with a head of 50 cm (see figure 1). The “Suction Capacity” values are measured with a vacuum gauge.



NOTE

the declared capacity of dry negative suction refers to the intake of fluids with a viscosity and specific weight equal to 1. The performance and duration of the pump’s membrane depend on the following factors:

- the fluid’s viscosity and specific weight;
- the length and diameter of the suction pipe and/or presence of suction bends on the product circuit;
- presence of abrasive solid particles.

NEGATIVE SUCTION: with fluids max up to 5.000 Cps at 20°C and a maximum specific weight of 1.4 Kg/l.

BELOW HEAD SUCTION: with fluids max up to 20.000 Cps at 20°C (see Pump model).

With higher viscosities, physical factors intervene that require a correct evaluation, therefore, it is always necessary to contact the Manufacturer’s Technical Department in advance.

The following tables show the Technical Data, the maximum overall dimensions, the clamping points and the weights; **for the dimensional values and the specific technical data of the supply, see the Technical Data Sheets of the specific model.**

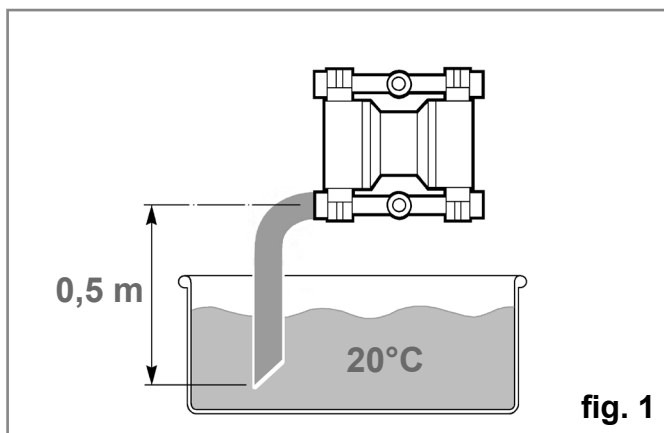

NEGATIVE SUCTION
Max 5.000 Cps a 20°C
(specific weight of 1.4 Kg/l)

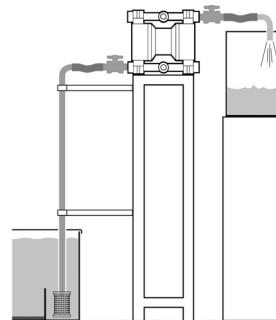

BELOW HEAD
Max 20.000 Cps a 20°C

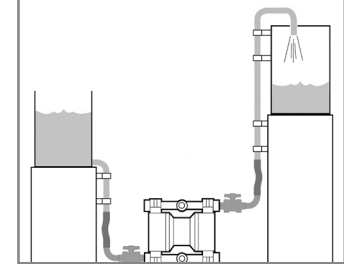

TECHNICAL DATA		unit of measurement	MA-MP 130	MA-MP 140	MA-MP 180	MA-MP 190
Suction/delivery fittings		inches	1/2" f	1" f	1" f	1 1/4" f
Air fitting		inches	3/8" f	3/8" f	3/8" f	1/2" f
Air pressure (MIN-MAX)		bar	2 - 8	2 - 8	2 - 8	2 - 8
Solids passing MAX		∅ mm	4	4	4	5
Dry suction capacity (PTFE diaphragm)		m	4	4	4	4
Max head (water 20°C)		m	80	80	80	80
MAX water flow rate 20°C (immersed suction manifold)		l/min	60	110	160	220
MAX fluid temperature (zone 1 - 21) (zone 2 - 22)	PP+CF	°C	65°	65°	65°	65°
	PVDF+CF	°C	80°	80°	80°	80°
	ALU - AISI 316	°C	80°	80°	80°	80°
MAX fluid temperature	PP	°C	65°	65°	65°	65°
	PVDF	°C	95°	95°	95°	95°
	ALU - AISI 316	°C	95°	95°	95°	95°
Weight (empty)	PP and PP+CF	Kg	3.6	5	7.5	12
	PVDF	Kg	4.2	6.5	9.5	14
	ALU	Kg	4	6.5	8.2	16
	INOX	Kg	--	10.5	12	23
Noise (5 bar rubber balls)		dB (A)	70	70	75	75

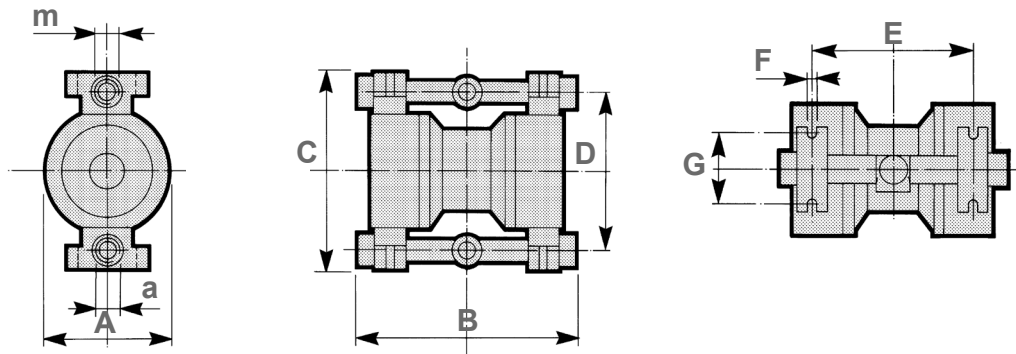

PUMP	MATERIAL	WEIGHT Kg	inches		DIMENSIONS mm						
			a	m	A	B	C	D	E	Ø F	G
MP 130	PP and PP+CF	3.6	1/2"	1/2"	153	246	240	201	168	6,5	85
MA 130	Aluminium	4	1/2"	1/2"	153	241	234	198	168	6,5	85
MA-MP 140	PP and PP+CF	5	1"	1"	170	308	274	219	213	6,5	92
MA 180	PP and PP+CF	7.5	1"	1"	202	329	325	263	228	8	110
MA 180	Aluminium	8.2	1"	1"	202	315	324	270	213,5	8	110
MA 190	PP and PP+CF	12	1 1/4"	1 1/4"	220	399	386	302	267	8	122
MA 190	Aluminium	16	1 1/4"	1 1/4"	220	394	385	302	265	8	122

CHAPTER 3

This chapter deals with very important topics on safety and how to safely install, use or maintain the MA-MP pumps.

Strictly follow these simple principles and rules throughout the life of the pump.

THIS PART INCLUDES THE FOLLOWING TITLES	PAGE
3.1 SAFETY RULES	21 - 24

The following sections describe how to behave.

3.1 SAFETY RULES



The Original Instructions must always be available to operators. Dangerous or hazardous practices or practice not complying with the Safety Rules and with the recommendations contained herein, may cause material damage, serious injuries and in extreme cases even death for which the Manufacturer cannot be held responsible.

- 3.1.1 All pumps undergo functional tests and are tested with water at 20°C before being shipped to the Customer, therefore, tap water residues can be found inside them.



CAUTION: danger of chemical reactions to water

Before installing the pump for use with liquids that react with tap water, it is necessary to open the product circuit and dry all internal surfaces.

- 3.1.2 The personnel in charge of installing, inspecting and maintaining the pump must have suitable technical preparation and knowledge of the product to be pumped and also have specialist knowledge on potentially explosive atmosphere and related risk for uses in ATEX areas.



CAUTION

These instructions are essential for the pumps' compliance to the requirements of the 2014/34/EU and must therefore be: available, known, understood and used by all Operators.

- 3.1.3 Use of the pumps in a manner that does not comply with the instructions indicated in the Manufacturer's use and maintenance manual will cancel all the requirements for safety and protection against of explosions.



CAUTION

The maximum allowed temperature for process fluids (in zone 1 and zone 21) is equal to 65°C or 80°C depending on the construction materials of the pump; **if exceeded, compliance with the affixed ATEX and IECEx marking is not ensured.**

- 3.1.4 The air supply to the pump must always entail the installation of a suitable on-off valve (Emergency), 3-way valve and check valve and the pressure must never be less than 2 bar or greater than 8 bar. The pneumatic motor of the MA-MP pumps is self-lubricated (no further lubrication is required); feed the pump with dry and NON-lubricated filtered air. It is FORBIDDEN to feed the pump with lubricated, unfiltered and/or undried air.



CAUTION: danger of fluid entering the compressed air circuit and being discharged into the environment.

Installing the pump without on-off, 3-way or check valves on the air supply piping to prevent the pumped liquid from entering the pneumatic circuit if the diaphragms are broken is forbidden. Even in battery installations, the check valve must be installed on each pump.

- 3.1.5 The air of the pump's pneumatic circuit must always be discharged in a free, non-dusty atmosphere and free of saturated vapours that can damage the internal circuit.



CAUTION: danger of damage to the internal pneumatic circuit.

For installations with the pump immersed or operation in environments with a heavy atmosphere (dusts, vapours or saturated vapours), it is necessary to install a pipe and fittings (of suitable materials) to bring the air discharge point outside the environment/process liquid.

- 3.1.6 For pump installations with high delivery heads, very dense fluids, with high specific weight and/or with strong back-pressures, the pneumatic circuit discharges may freeze.



CAUTION: danger of air discharge freezing and loss of efficiency and/or pump stop.

Provide for the installation of a glycol adder on the air supply line, upstream of the pump.

- 3.1.7 Where the user presumes that the temperature limits set forth in this manual may be exceeded, a protective device must be installed on the system to prevent the maximum allowed temperature from being reached.



CAUTION: danger of loss of conformity with the affixed ATEX and IECEx marking.

It is forbidden to use the pump with temperatures higher than those allowed and specified in the manual; **if exceeded, conformity with the affixed marking is not guaranteed.**

- 3.1.8 It is always necessary to carefully check the suitability of the chemical compatibility and temperature of the fluid to be pumped (if necessary by subjecting it to prolonged tests) before installing and using the pump.



CAUTION: danger of chemical reactions and possible breakage or product leakage.

It is forbidden to use the pump with fluids that are not compatible with the component materials.

- 3.1.9 Loads that burden on the pump, together with fluids or uses in corrosive environments in contact with some materials, can cause stress corrosion cracking (material deterioration due to the combined action of corrosion and application of a constant load). This often leads to sudden and unexpected breakage (not attributable to construction defects) of the components subjected to stress in corrosive environments, especially with high temperatures.



CAUTION: danger of stress corrosion cracking and sudden breakage with product leakage.

In the presence of stress corrosion cracking, the user must check complete compatibility (over time) with the construction materials of the pump or, if necessary, make a more suitable choice of construction material and follow the Manufacturer's instructions during the installation to eliminate the loads.

- 3.1.10 Pumps with Aluminium components or parts cannot be used for pumping III-trichloroethane, methylene chloride or solvents based on other halogenated hydrocarbons.



CAUTION: danger of explosion.

Aluminium in contact with III-trichloroethane, methylene chloride or solvents based on other halogenated hydrocarbons generates dangerous chemical reactions.

- 3.1.11 MA-MP pumps are not self-draining, therefore, if fluids are used that crystallise, once stopped, it is always necessary to promptly wash the inside with suitable clean washing liquid.



CAUTION: danger of pump stoppage.

The prolonged shutdown of the pump containing fluids that crystallise, can cause the valves and diaphragms to stick and malfunction.

- 3.1.12 When using the pump with aggressive or toxic liquids or with liquids that may represent a health hazard, you must install a suitable protection on the pump to contain, convey and collect the product in a safe area and signal any spills.



CAUTION: danger of pollution, contamination, injuries or, in extreme cases, death.

It is forbidden to install the pump in the absence of a suitable protection for the containment and collection of aggressive or toxic liquids or with liquids that may represent a health hazard.

- 3.1.13 Installation requires suitable valves (with larger diameter than the pump) for the interception and sectioning of the product upstream and downstream of the pump, to allow safe operation in case of anomalies and/or disassembly.



CAUTION: danger of uncontrolled product leakage.

Installing the pump without suitable on-off valves on the intake and delivery sides is forbidden.

- 3.1.14 The pump does not perform valve functions and does not ensure the seal against the non-return of the fluid. In the event of installation with high delivery head and/or with fluid of a high specific weight, it is necessary to install a suitable check valve (suitably sized) on the duct near the pump.



CAUTION: danger of uncontrolled product leakage.

Installations with high delivery head and/or with fluid of a high specific weight, can generate strong back-pressures that prematurely wear the diaphragms and/or cause a possible breakage.

- 3.1.15 In installations where the presence of solid particulate suspended in the product is foreseen, install a suitable strainer on the suction inlet, with a surface area of 2.5 or 3 times the area of the suction pipe and passages smaller than the size of the particulate allowed by the pump.



CAUTION: risk of damaging the pump

Installing the pump without a suitable strainer or with an insufficient and undersigned fluid flow rate and/or passage larger than the particulate allowed by the pump model is forbidden.

- 3.1.16 In general, all fittings, ducts and valves and/or filters installed along the entire air circuit and product circuit, upstream and downstream of the pump, must never have a flow rate lower than the nominal values of the pump.



CAUTION: risk of diaphragm breakage and product leakage

In addition to determining poor efficiency and performance, the presence of flow rate points lower than the nominal values of the pump along the product circuit ducts, upstream and downstream of the pump, can prematurely wear the diaphragms and/or cause breakage.

- 3.1.17 To install the pump, use fittings with cylindrical gas threads, made of the same construction material as the pump. In general, all the pump threads for connection with the fluid suction and delivery ducts are not intended to ensure hydraulic seal; to ensure hydraulic seal, use suitable seals.



CAUTION: risk of thread breakage and product leakage.

It is forbidden to use fittings with tapered threads or made with a construction material other than that used for the pump.

The tightening of the suction and delivery fittings must ensure the mechanical seal of the ducts while to ensure the hydraulic seal, use suitable seals.

- 3.1.18 Using the pump in a potentially explosive environment must always provide for an efficient earthing of the same, regardless of any organ connected to it.



CAUTION: risk of explosions due to electrostatic charges.

Lack of earthing or incorrect earthing of the pump, will cancel the requirements for safety and protection against the risk of explosion provided for by the affixed ATEX marking. It is forbidden to use pumps made of non-conductive material (which is electrostatically charged) for flammable liquids, and/or without adequate earthing.

- 3.1.19 The presence of vortices on the suction point creates cavitation and malfunction. During operation, check for any abnormal noise and that the outlet fluid does not contain "gas".



CAUTION: in the event of abnormal noise, stop the pump immediately.

Abnormal noise or the presence of "gas" in the fluid exiting the pump indicate an anomalous conditions for which it is always necessary to determine the cause before continuing use.

- 3.1.20 Depending on the configuration, place of installation of the pump and duration of exposure near it, it is necessary to detect the emitted noise.



CAUTION: risk of exposure to noise.

If necessary, use suitable sound-absorbing barriers and/or Personal Protective Equipment (such as sound-absorbing caps or headphones).

- 3.1.21 The diaphragms, (internal and in contact with the product) are components subject to wear. Their duration is strongly affected by the conditions of use and by the chemical and physical stresses to which they are subjected. From tests carried out on thousands of installed pumps (with head equal to 0.5 m at 20°C), it was found that the duration exceeds 100,000,000 (one hundred million) cycles.



CAUTION: risk of diaphragms breaking.

For safety reasons, the pump diaphragms must be disassembled and checked **every 10,000,000 (ten million) cycles and their replacement every 20,000,000 (twenty million) cycles.**

- 3.1.22 The operation of the pump must be adjusted only by choking the supply of compressed air by means of the adjustment valve or flow regulator.



CAUTION: risk of premature wear and/or diaphragm breakage.

It is forbidden to close or choke the sectioning valves of the product suction duct during pump operation. Changing the general performance and head of the pump and/or subjecting the diaphragms to strong stress affects their duration.

- 3.1.23 The pneumatic exchanger components (shaft included), are built with materials that are not specifically resistant to chemical and corrosive products; if the diaphragms brake, the fluid can enter the pneumatic exchanger and the environment through the discharge circuit and damage the components.



CAUTION: damage of the pneumatic exchanger.

If the diaphragms break, and come into contact with corrosive fluid, it is necessary to completely replace the pneumatic exchanger.

- 3.1.24 The presence of dust and/or deposits on the external and internal surfaces of the pump can negatively affect the process temperatures. In environments with a potentially explosive atmosphere, it can even compromise safety and cancel the requirements envisaged by the affixed ATEX and/or IECEx marking. The pumps must not be installed and/or exposed to sand and/or pressurised abrasive material that could damage the external plastic parts.



CAUTION risk of overheating and/or fire

It is necessary to periodically verify the absence of dust and/or deposits from the external and internal surfaces of the pump and, if necessary, remove and clean with a damp cloth. It is forbidden to use the pump for pumping powders and dehydrated and/or solid materials of any type and kind (flammable and non).

- 3.1.25 The silencer and the compressed air supply fitting must be disassembled in the absence of dust. Before disassembling, clean the outside of the pump to prevent deposits and impurities from entering the air circuit.



CAUTION: risk of damage to the pneumatic exchanger.

Before reassembling the silencer and the compressed air supply fitting on the pump, make sure that there are no deposited impurities or dust that can enter the pneumatic distributor of the pump.

- 3.1.26 In severe conditions, the pump can reach significant external temperatures (Max 70°C) during its intended operation, in these cases it is necessary to provide a suitable guard and/or suitable marking to signal the residual risk.



CAUTION: risk of high temperatures and/or burns.

Before intervening or coming into contact with the external surfaces of the pump, it is recommended to wait for it to cool and / or wear protective gloves.

- 3.1.27 Before disassembling the pump, the residual pressure of the internal pneumatic circuit must always be discharged by operating as described in Section "5.2 PUMP STOP".



CAUTION: risk of internal back-pressures and projection of components during disassembly.

In severe conditions (incorrect installations and/or stops and/or in stall conditions), residual pressures inside the pump can be generated which are not discharged. Before opening and disassembling the pump, it is necessary to secure the pump casings with suitable ratchet straps.

- 3.1.28 Aggressive, toxic or dangerous fluids can cause serious physical injuries and/or dangerous harm to health. Always wash and empty the internal circuit of the product and wash and treat the pump, before disassembling, storing and / or shipping it to the Manufacturer.



CAUTION: risk of injuries or harm to health.

It is forbidden to dismantle, store, and/or return to the Manufacturer or to a Service Center the pump with product residues, or if it is not adequately washed and decontaminated.

In addition to performing their primary function, the components of the MA-MP pumps are designed and built to meet important functions that affect the general safety of the pump; **use only Original spare parts to replace worn parts.**

Failure to comply with the above can give rise to risks for the Operator, Technicians, people, pump and/or the environment where it is installed, that cannot be attributed to the Manufacturer.

MA-MP pumps are normally shipped in a cardboard box or, at the Customer's request and the place of dispatch, they can be supplied on pallets with wooden crates or in packaging for shipment by sea.

THIS PART INCLUDES THE FOLLOWING TITLES		PAGE
4.1	STORAGE AND PRESERVATION	26
4.2	TRANSPORT AND HANDLING	27
4.3	POSITIONING AND INSTALLATION	28
4.4	PNEUMATIC CONNECTION	31
4.5	CHECKS PRIOR TO COMMISSIONING	33

Below is a description of how to behave in each of the cases described above.

4.1 STORAGE AND PRESERVATION



MA-MP pumps are normally shipped in a closed cardboard box and internal cardboard shockproof protection.

At the specific request of the Customer, depending on the quantities and country of destination, they can be shipped on pallets, in wooden crates or with packaging for shipments by sea.

The packaged pump can be store for up to 6 months in a marine environment (protected, dry and clean) and 12 months in a terrestrial environment (clean, protected and dry), at temperatures from +5°C to +45°C, with relative humidity not exceeding 90%.

When the supply is received, check that the packaging and the pump are intact and have not been damaged, then it is possible to arrange for storage or assembly.

4.1.1 OPERATIONS FOR FUTURE STORAGE

In the future, the pump must always be stored with the pump empty, without liquids and after having suitably washed it.

4.1.1a Drain the pump of any liquid residues.

4.1.1b Wash the internal and external surfaces of the pump and provide for its decontamination if dangerous or toxic liquids have been used.



CAUTION: risk of pump damage.

The pump must be stored in a suitable packaging, protected from sunlight and dust, away from substances that react with the construction materials.

4.1.2 OPERATIONS AFTER STORAGE/PROLONGED STOPS, BEFORE OPERATION

After a prolonged storage and/or stop, it is always necessary to perform the following checks before commissioning the pump:

4.1.2a Check that the pump screws are tight as described in *Section 6.3 TIGHTNESS CHECK*.



CAUTION: risk of damage and breakages.

Excessive tightening (especially on plastic pumps), can cause dangerous tensions on some components and/or sudden breakages that cannot be attributed to construction defects.

4.1.2b Carry out an initial check of the pump's no-load operation and pay attention to the correct operation of the pneumatic exchanger and the absence of abnormal noises.



CAUTION: in the event of abnormal noise, stop the pump immediately.

An abnormal noise from the pump indicates an irregular condition for which it is always necessary to determine the cause before continuing; **in such cases, immediately stop the pump and resolve the anomalous condition before commissioning.**

4.2 TRANSPORT AND HANDLING



These operations are exclusively reserved for handling personnel equipped with adequate Personal Protective Equipment (PPE) such as: protective gloves, safety shoes and protective clothing.



CAUTION: risk of tipping and crushing.

The load inside the packaging can be unbalanced, therefore, do not use lifting equipment and gripping points other than those indicated on the packaging.

When the supply is received, check that the packaging and the pump are intact and have not been damaged, then:

4.2.1 Raise the supply using hoists of adequate capacity for the weight, respecting the instructions on the packaging. With slow movements, handle the supply and transport it keeping it at a minimum height from the ground and place it near the place of installation (dry and covered). Remove the hoist.

4.2.2 Open the packaging and take the use and maintenance manual and work as described.



CAUTION: danger of pollution.

Do not disperse the packaging into the environment, but contact specific authorised disposal companies.

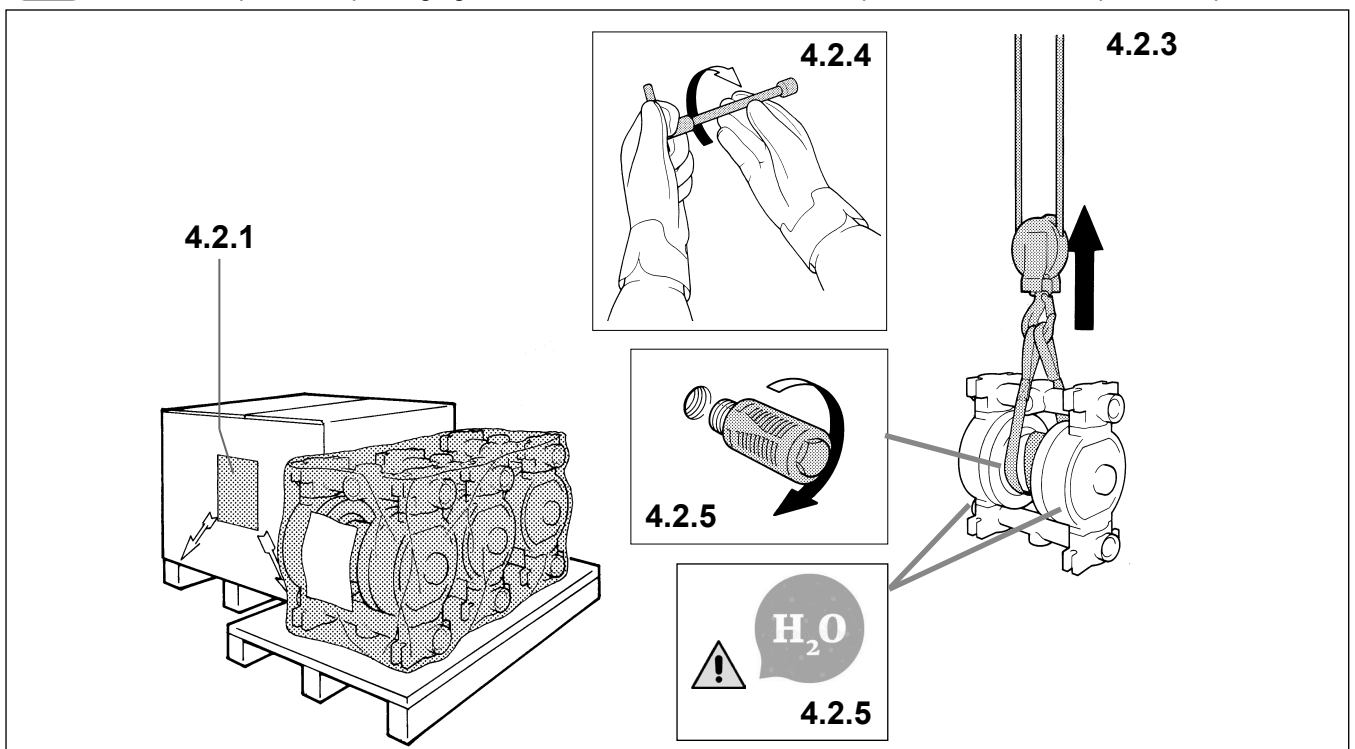

4.2.3 Raise the pump using suitable loading equipment depending on the indicated weight.

4.2.4 Check that all the pump screws are tight, respecting the tightening torques shown in *Section 6.3 TIGHTNESS CHECK*.



CAUTION: risk of stress corrosion cracking phenomena and breakages.

Excessive tightening (especially on plastic pumps), can cause dangerous tensions on some components and sudden breakages that cannot be attributed to construction defects.

4.2.5 If the pump has been shipped with the air discharge silence disassembled, provide for its assembly.



CAUTION: risk of chemical reactions to water

Before installing the pump for use with liquids that react with tap water, it is necessary to open the product circuit and dry all internal surfaces.

4.2.6 Raise the pump and move it to the place of installation.

Pump handling is complete.

4.3 POSITIONING AND INSTALLATION



The installation operations are reserved for qualified and authorised Installers, equipped with suitable Personal Protective Equipment (PPE), who know and comply with the contents of this Manual. Since an endless variety of products and chemical compositions exists, the user is presumed to have the best knowledge of their compatibility and reaction with the pump's construction materials. Before using and installing the pump, all necessary checks and tests must be performed with great care to avoid even the slightest risk, an event that the Manufacturer cannot foresee and for which he cannot be held responsible.

General installation requirements

- Adequate space to allow future maintenance;
- Pump installation with axis horizontal;
- Tightening on rigid supports (to ceiling or floor) with flatness (0.1 mm);
- With negative head for fluids with Max density up to 5,000 Cps at 20°C and a Max specific weight of 1.4 Kg/l;
- Installations with positive head for fluids with Max density up to 20,000 Cps at 20°C;
- Positioning near the point of collection (max 10 times the suction diameter);
- Suction inlet away from vortices;
- Earthing of the pump for installations in a potentially explosive environment;
- Pneumatic circuit supply with dried, non-lubricated water;
- Installation of an on-off valve, 3-way valve and check valve on the air supply.

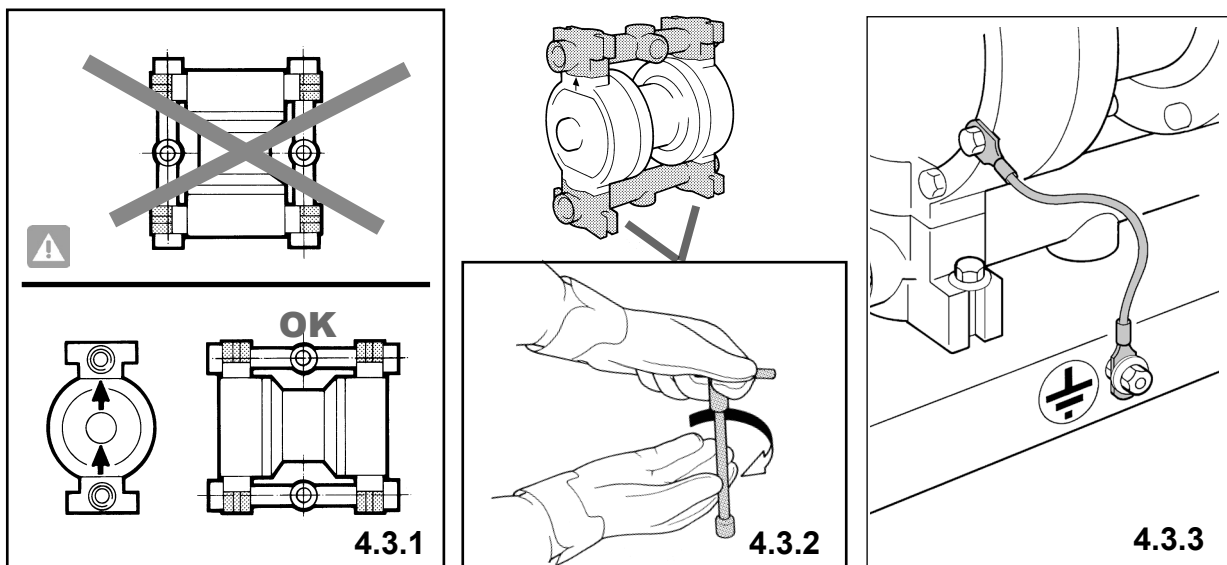

- 4.3.1 Position the pump with the axis horizontal at the place of installation, as close as possible to the point of collection, aligning it with the suction and delivery ducts.



NOTE

The product delivery manifold must always be positioned in the upper area; **the arrows on the pump casing must always be facing up.**

- 4.3.2 Provide for the tightening on rigid supports (to ceiling or floor with suitable flatness 0.1 mm) on feet with appropriate washers and bolts. If necessary, provide suitable anti-vibration feet (PIUSI Catalogue).

Pump positioning is thus completed.

PRODUCT CIRCUIT CONNECTION

After positioning, it is possible to connect the pump to the product circuit as follows:



CAUTION: danger of chemical reactions to water

Before installing the pump for use with liquids that react with tap water, it is necessary to open the product circuit and dry all internal surfaces.

Product system piping requirements

- The connection fittings must be made of the same material as the pump with cylindrical threads (do not use tapered threads);
- Pump connection must include a piece of flexible hose with a metal core (do not attach the pump directly with rigid pipe);
- all flexible hoses present must be reinforced with a metal core;
- Piping must be self-supported and must not burden on the pump;
- Correct sizing of the ducts (suction and delivery) for correct suction speed;
- Product on/off valves (suction and delivery, that do not cause pressure drops);
- With suspended particulate, install a correctly sized strainer on the suction (surface 2.5 / 3 times the suction section of the pump with maximum allowed slot);
- With products that crystallise, provide a washing a circuit (with compatible products);
- Product ducts clean inside and without solid processing residues (shavings, particulates, etc.).

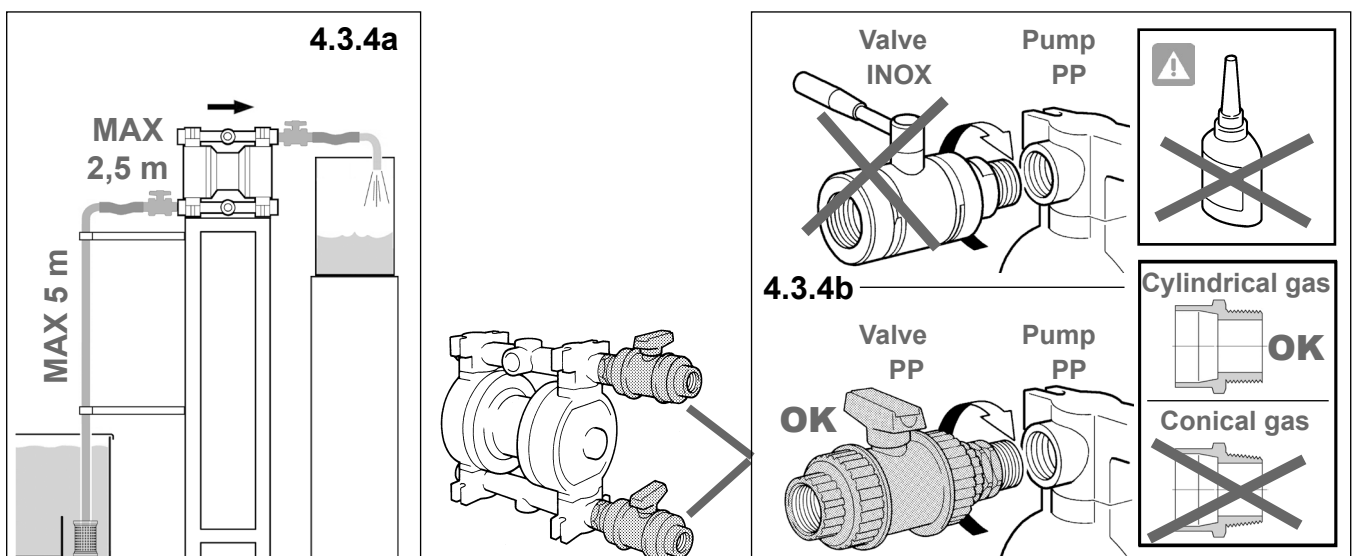

4.3.2a Diaphragm pumps with negative suction are affected by the following factors:

- Fluid viscosity - specific fluid weight - diameter - length and/or bends on the suction.

Position the pump as close as possible to the point of collection (within 2.5 m) and in all cases, never higher than 5 m vertically. The suction pipe diameter must never be smaller than that of the pump connection; it must be suitable sized as the distance or viscosity of the fluid increases.



CAUTION: risk of premature wear and/or diaphragm breakage.

The fluid to be pumped with negative suction must never exceed a viscosity of 5,000 Cps at 20°C and a specific weight of 1.4 Kg/l.

With higher viscosities, physical factors intervene that require a correct evaluation, therefore, it is always necessary to contact the Manufacturer's Technical Department in advance.

4.3.2b MA-MP pumps are supplied with the product connection seats with Cylindrical gas threads. For connections to the pump manifolds, only use fittings with cylindrical gas threads (non-tapered) of the same material as the pump.

Example: (PP pump = PP fittings) or (INOX pump = INOX fittings).

On the delivery and discharge manifold install a manual valve of the same diameter as the pump inlet (never smaller) or larger for negative suction or for fluids with high viscosity.

If necessary, load two turns of PTFE tape on the thread and tighten the valves onto the pump manifolds (with moderate clamping pressure) until the seal is ensured.

CAUTION: risk of breakage and/or yielding of the threads.
Do not use threadlockers and/or Teflon paste and conical threads. Excess PTFE tape and/or excessive clamping pressure can cause cracks on the manifolds and/or yielding of the threads.

4.3.2c In the event of a vertical product delivery higher than 5 meters, it is necessary to install a check valve on the system piping, to prevent the fluid from burdening inside the pump.

4.3.2d Install the sleeves to secure the flexible hoses on both valves.

CAUTION: do not attach the pump DIRECTLY with rigid pipe.
For negative installations and/or fluids with high viscosity, use hoses with an OVERSIZE DIAMETER, especially on the intake side. The filters or other equipment installed at the intake side must be suitably dimensioned in order to avoid pressure drops.

4.3.2e Connect the flexible hose with a metal core on the relative product suction and delivery connections, respecting the arrows on the pump casing, which must always face upwards.

CAUTION
Check that the connection piping to the pump are is clean inside and do not contain solid or processing residues.

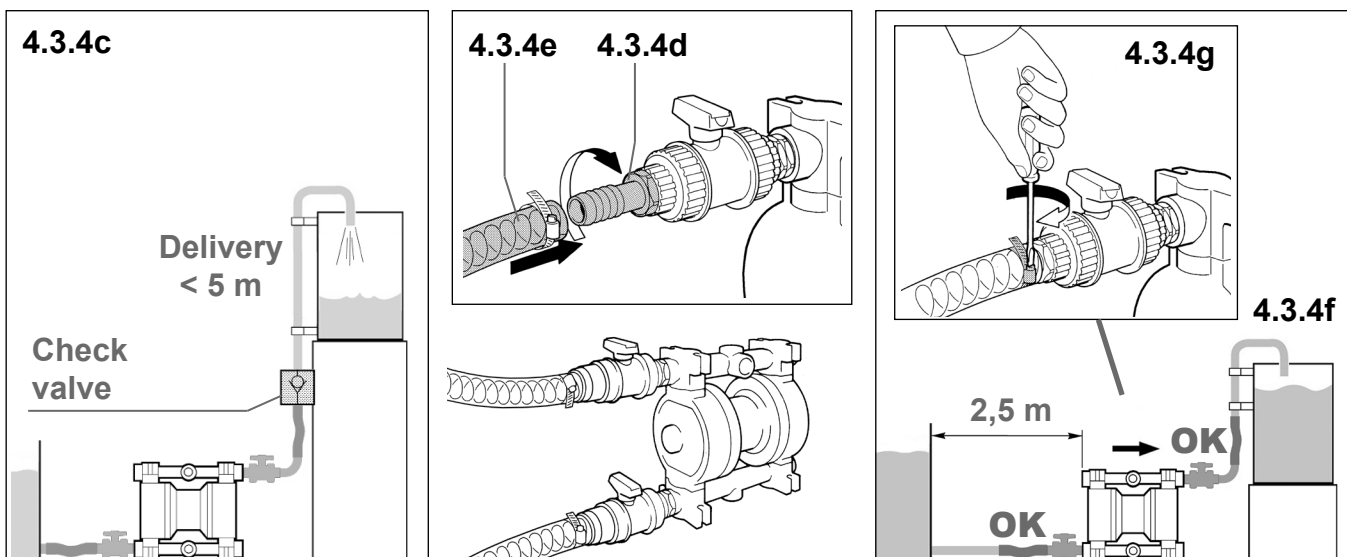

4.3.2f Connect the flexible hoses to the rigid ducts (suction and delivery) of the system.

CAUTION: danger of stress corrosion cracking.
Check that the system ducts are fixed and self-supporting and that they do not burden on the pump. Pay particular attention to stress corrosion cracking phenomena. The pump material may deteriorate due to the combined action of corrosion and application of a load, which may cause parts subjected to stress to break suddenly and unexpectedly, especially at low temperatures.
The pipes must be strong enough so as not to deform under suction and must never burden on the pump and vice versa.

4.3.2g Fix flexible hoses on the pump and on the system with appropriate hose clamps.

CAUTION: risk of premature wear and/or diaphragm breakage.
Apart from the on-off valve, do not install any other components on the pump suction (couplings, elbows, valves, filters, coiled flexible hoses, etc.) which could compromise the pump suction performance and cause the premature breakage of the diaphragms. **The product on-off valves must always be fully open during operation (never choked).**
With high negative heads and/or high viscosity (if necessary), the pump must be pneumatically fed gradually using a "soft start" valve.

4.3.2h If used for drum suction (not below head), the submerged end of the intake hose must be provided with a diagonally cut fixing to prevent it from adhering to the drum bottom.

The product circuit connection is thus completed.

4.4 PNEUMATIC CONNECTION



The connection operations to the pneumatic system are reserved for qualified and authorised Installers, equipped with suitable Personal Protective Equipment (PPE), who know and comply with the contents of this Manual. After completing the installation, it is possible to connect the pump to the pneumatic supply circuit as follows:

Pneumatic system requirements

- Supply with non-lubricated, dried air, with suitable pressure (Min 2 bar - Max 8 bar);
- Use of pneumatic components with air flow rates suitable for the pneumatic circuit of the pump;
- Glycol adder for installations with strong delivery heads and/or back-pressures;
- Installation of an on-off valve, 3-way valve and check valve on the air supply;
- Installation of an air discharge pipe (with collection) outside environments with a heavy and potentially explosive atmosphere and for pumping flammable or toxic fluids.

4.4.1 Remove the adhesive sticker from the air connection of the pump.



CAUTION: danger of pump blocking.

MA-MP pumps must be pneumatically fed using NON-LUBRICATED, FILTERED AND DRIED compressed air at a pressure of no less than 2 bars and not more than 8 bars.

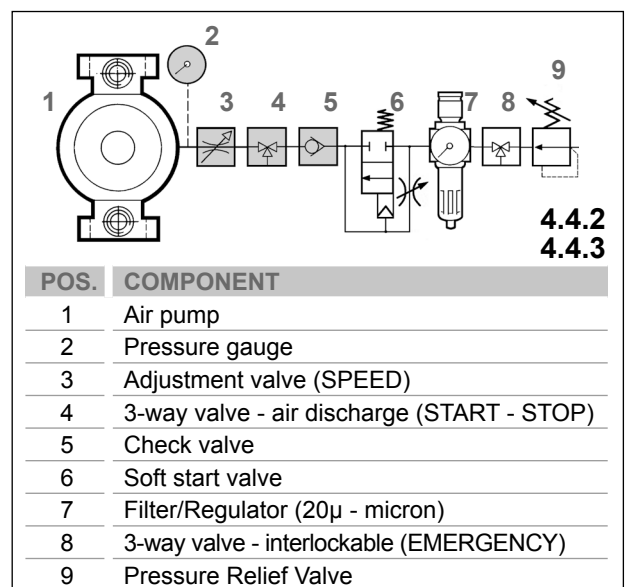
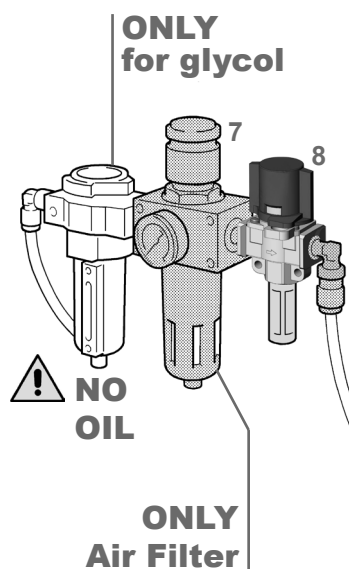
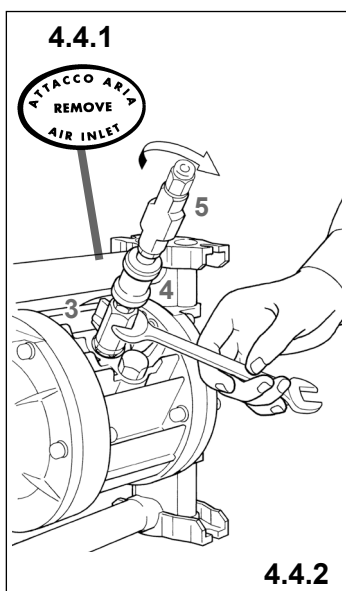

4.4.2 Tighten a compressed air flow control valve, a 3-way valve (START - STOP with air discharge) and a check valve on the pneumatic circuit connection of the pump, as per the diagram in the figure. Install a pressure gauge on the compressed air connection of the pump itself and check the value with the pump running to check the real pressure of the supply air.



CAUTION: danger of fluid entering the compressed air circuit and being discharged into the environment.

Do not install the pump without the 3-way valve (START - STOP) and/or the check valve to prevent the pumped fluid from entering the pneumatic circuit if the diaphragms break.

Even in battery installations, the check valve must always be installed on each pump.

4.4.3 Install a 3-way EMERGENCY stop valve upstream of the pneumatic supply circuit (disconnecter with interlock) in a protected and easily accessible position.

4.4.4 Installations where operation with many Start / Stop cycles is expected (with high delivery heads and / or with strong back-pressures) require the installation of a pneumatic soft start valve to protect the product diaphragms.



NOTE

The installation of the soft start pneumatic valve, in addition to allowing a more uniform and fluid pumping of the product during the start-up phase, allows the protection of the diaphragms and preserves the operating life of the pump.

- 4.4.5 For pump installations with high delivery heads and/or with strong back-pressures, the pneumatic circuit discharges may freeze.



CAUTION: danger of loss of efficiency and/or pump stop.

With strong heads and/or high viscosity, provide for the installation of a glycol doser on the air supply line, upstream of the pump.

- 4.4.6 The air of the pump's pneumatic circuit must always be discharged in a free, non-dusty atmosphere and free of saturated vapours that can damage the internal circuit. In the event of total rupture of the diaphragms, the fluid can enter the pneumatic circuit, damage it and exit from the drain.



CAUTION: danger of damage to the internal pneumatic circuit.

For installations with the pump immersed or for operation in environments with a heavy atmosphere (dusts, vapours or saturated vapours), it is necessary to install a pipe and fittings (of suitable materials) to bring the air discharge point outside the environment/process liquid.



CAUTION: risk of fluid leaking in case of breakage of the diaphragms.

In installations for pumping flammable (allowed by the marking), corrosive, toxic or dangerous fluids, the air discharge must be conveyed in suitable piping to a safe collection area.

- 4.4.7 Connect the compressed air supply pipe to the pump circuit.

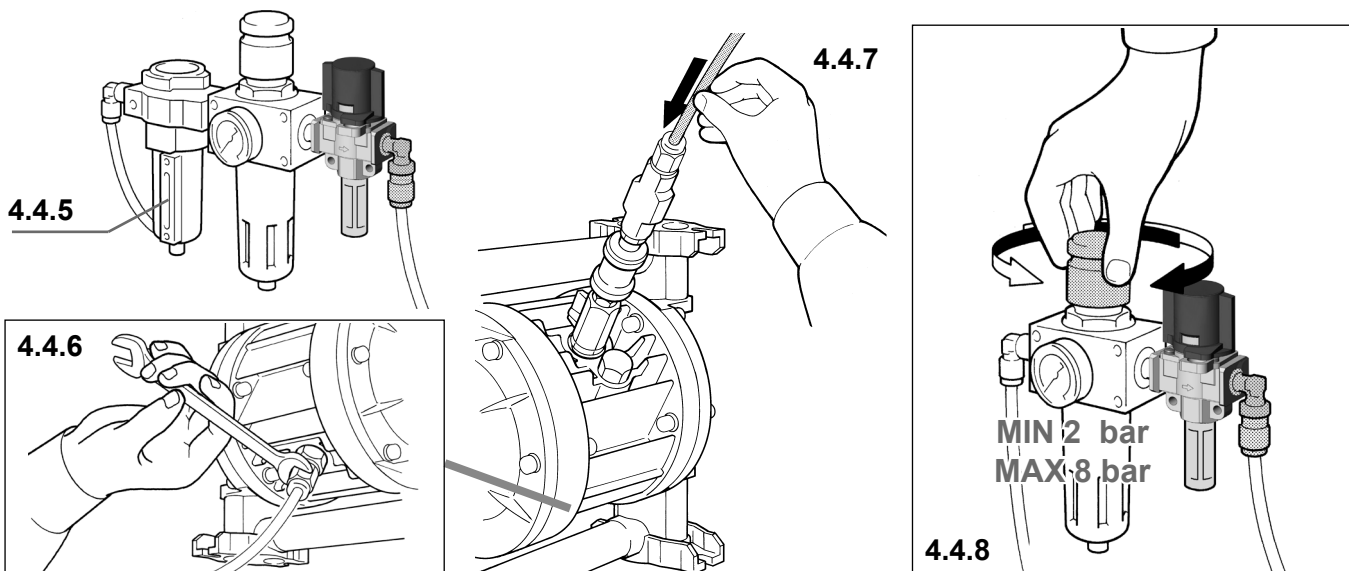

CAUTION: risk of pneumatic pressure drop.

Use pipes, accessories and control and regulation elements with flow and pressure characteristics suitable for the characteristics of the pump in order not to cause pressure drops. **Pay attention to snap-on fittings: most of them cause pressure drops.**

- 4.4.8 Adjust the network pressure of the compressed air to guarantee a pressure of not less than 2 bars and not more than 8 bars when the pump is running. **For MA-MP pumps equipped with rubber balls, do not exceed 5 bars.**



CAUTION: risk of stalling and/or diaphragm breakage.

To feed more than one pump with the same air control device, please contact the PIUSI Technicians. Lower or higher pressures may cause functional problems or pump breakage, product spills and damages to persons and/or objects.

- 4.4.9 If the pump is equipped with a STROKE COUNTER (to detect and/or view the number of pump cycles), provide for the electrical connection.

- 4.4.10 Always protect the pump from possible accidental blows and from contact with incompatible fluids that can damage it and/or react upon contact with it.

The pneumatic circuit connection and the pump installation are thus completed.

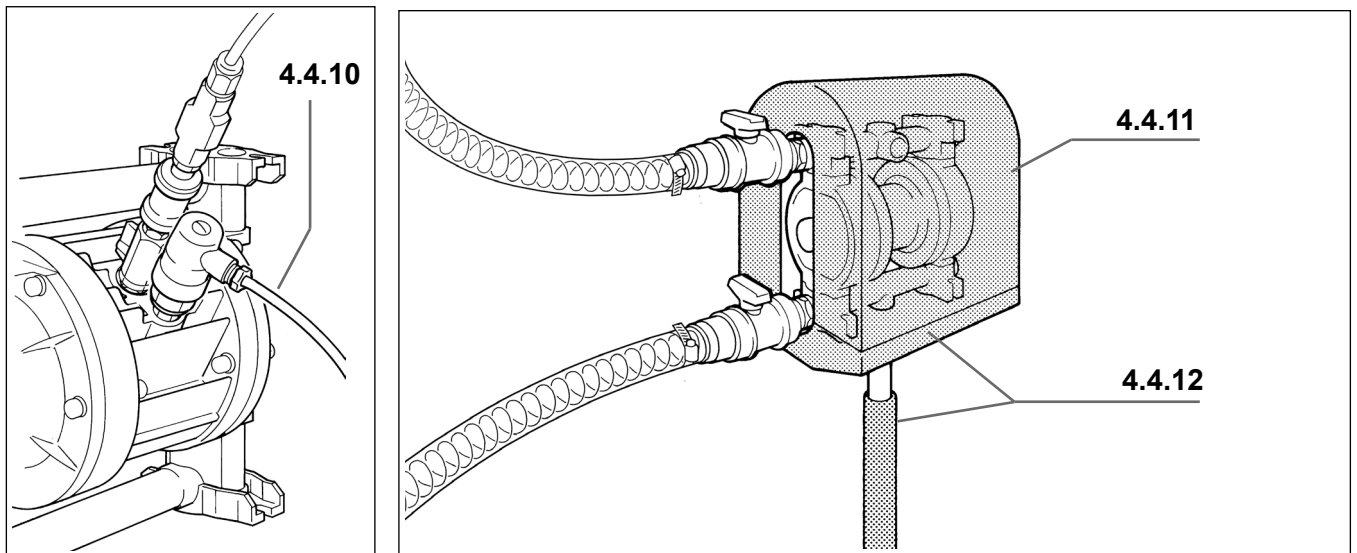

4.5 CHECKS PRIOR TO COMMISSIONING



Depending on the type of application, the type of fluid used, the installation/work environment, it is necessary to affix appropriate indications and indicate the residual risk present near the pump.



Before commissioning the pump, in order to verify that the installation actually meets the intended operating conditions, it is essential to carry out the following checks with the pump running:

- 4.5.1 With a pressure gauge positioned directly on the air inlet of the pump (downstream of all devices and fittings installed on the supply line), check that the detected pressure does not have any pressure drops compared to the reading on the pressure gauge of the filter of the pneumatic network supply line.
- 4.5.2 With a pressure gauge directly on the delivery manifold of the pump, check that the actual pressure of the pumped fluid at the pump outlet is correct compared to the Technical data of the installed Model.

The pump is ready for commissioning.

CHAPTER 5

The topics in this chapter are divided into sections, taking into account the operational phases for commissioning, operation and stop methods.

THIS PART INCLUDES THE FOLLOWING TITLES		PAGE
5.1	COMMISSIONING AND OPERATION	35
5.2	NORMAL STOP OF THE PUMP	37
5.3	EMERGENCY STOP OF THE PUMP	38

Below is a description of how to behave in each of the phases listed above.

5.1 COMMISSIONING AND OPERATION



The start-up and commissioning of the pump is reserved for trained and authorised Installers, who know and follow the Original Instructions.

The user must always use fluid compatible with the original design conditions of the pump itself and the affixed ATEX or IECEX marking.



CAUTION: risk of damaging the pump and product leakage and/or explosion.

It is forbidden to use the pump with fluids that are not compatible with the construction materials of the components or in an environment with the presence of incompatible fluids and atmosphere.

Proceed as follows to commission the pump:

Pump start-up requirements

- Presence of fluid in the collection tank;
- Fluid to be pumped compatible with the chemical characteristics and temperature of the construction material of the pump and the affixed ATEX or IECEX marking;
- Suction and delivery circuit running and no maintenance on the system;

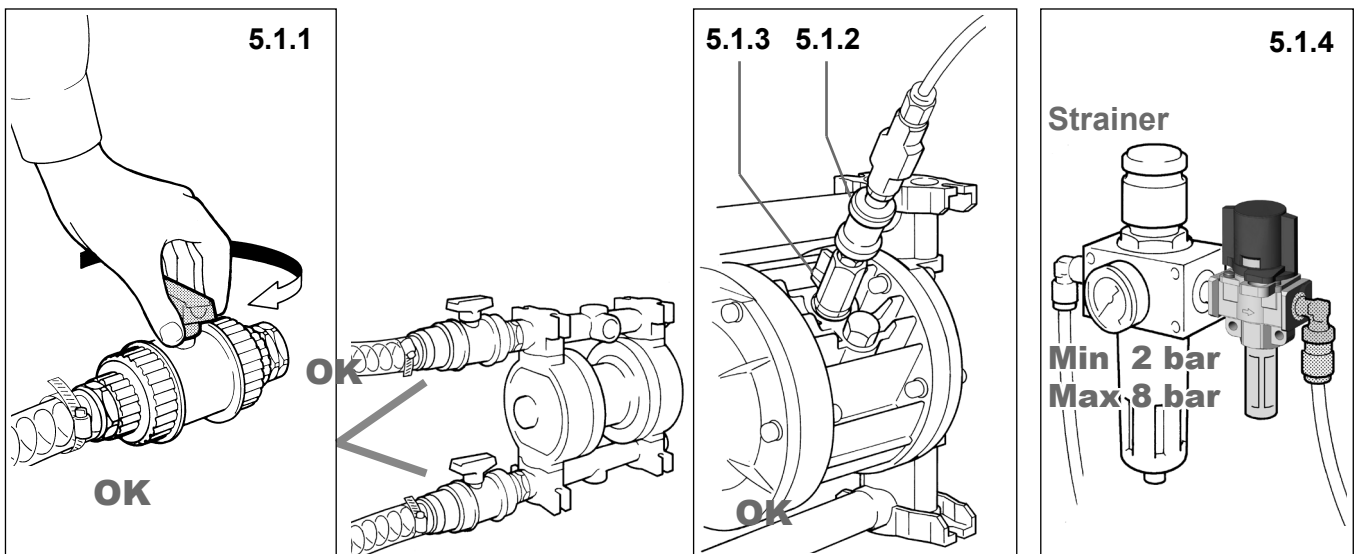

- 5.1.1 Open the product sectioning valves of the suction and delivery pipes.



CAUTION: risk of premature wear and/or diaphragm breakage.

It is forbidden to start the pump with the product valves (suction and delivery) closed or choked.

- 5.1.2 Open the 3-way pneumatic valve on the pump.

- 5.1.3 Gradually open the compressed air control valve mounted on the pump connection; the pump will start working.

- 5.1.4 Check and suitably adjust the air pressure on the network (with the pump running): MIN 2 bar MAX 8 bar.



CAUTION risk of stalling and/or premature wear and/or diaphragm breakage.

The pump may STALL with pressures below 2 bar (with the pump running). With pressures higher than the MAXIMUM threshold (Max 8 bar), yielding, pressurised product leakage and/or pump breakage may occur.

5.1.5 If an adjustment of the pump speed is required according to the viscosity of the fluid to be pumped, it is possible to operate in two different ways:

5.1.5a Adjust the network air supply pressure;

5.1.5b Choke the air volume (flow rate) using the air control valve on the pump.

 **CAUTION: risk of premature wear and/or diaphragm breakage.**
Do not close or operate on the product suction valve to choke the fluid.

5.1.6 Check that there is no abnormal noise during operation and that “gas” is not present in the outlet fluid; the presence of vortices on the suction point creates cavitations and malfunctions. Besides being damaging for the pump, cavitation is particularly dangerous in a potentially explosive atmosphere: it is necessary to check that the pump has been correctly sized; **if in doubt, do not hesitate to contact the PIUSI Technicians.**

 **CAUTION: risk of damaging the pump and/or premature wear/diaphragm breakage.**
An abnormal noise or the presence of “gas” in the fluid exiting from the pump indicate an abnormal condition for which it is always necessary to determine the cause before continuing; **in such cases, immediately stop the pump and resolve the anomalous condition before continuing.**

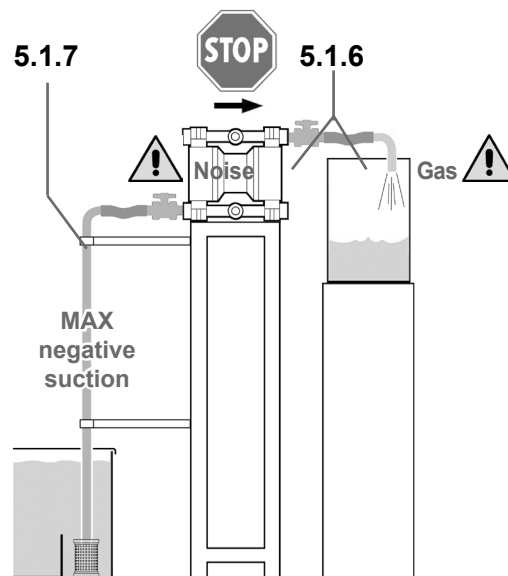
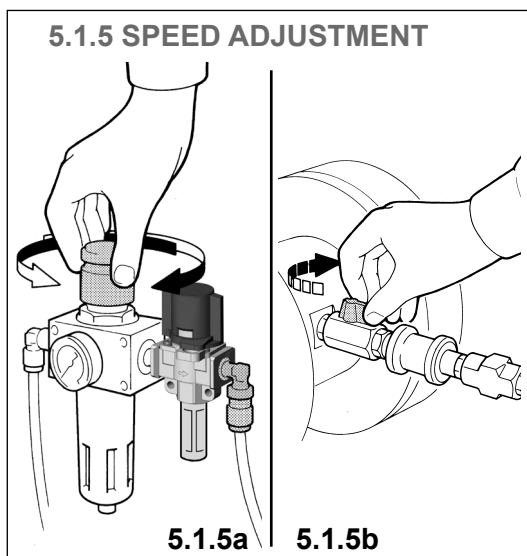

5.1.8

5.1.7 If the installed pump has negative suction or used with highly viscous fluid, reduce the pump speed by acting on the air control valve. Unprimed pumps have a negative suction capacity that varies according to the type of diaphragm and packing mounted; **CONTACT THE MANUFACTURER’S CUSTOMER ASSISTANCE SERVICE FOR FURTHER DETAILS.**

 **CAUTION**
For pumps with split manifold, do not use fluids with different viscosities; **stall, premature diaphragm and pneumatic circuit wear/breakage may occur.**

5.1.8 The diaphragms, (internal and in contact with the product) are components subject to wear. Their duration is strongly affected by the conditions of use and by the chemical and physical stresses. From tests carried out on thousands of installed pumps (with head equal to 0.5 m at 20°C), it was found that the normal duration exceeds 100,000,000 (one hundred million) cycles.

 **CAUTION**
For safety reasons, in environments with a potentially explosive atmosphere and for pumping flammable fluids (admitted by the marking), the pump diaphragms must be disassembled and checked every 10,000,000 (ten million) cycles and replaced every 20,000,000 (twenty million) cycles.

Perform the maintenance and replacements provided for by the Manufacturer on a regular basis.

5.2 NORMAL STOP OF THE PUMP



Do not stop pumping the liquid and/or the operating pump by closing the on/off valves of the product suction and/or delivery duct. The pump and fluid must always be stopped by stopping the pneumatic motor of the pump, by disconnecting the air.

Requirements after the normal stop of the pump

- After the normal stop of the pump, the liquids that crystallise must be discharged and the inside of the pump must be washed immediately after stopping;
- If the liquid to be processed is changed after the pump has stopped, it is necessary to perform draining and the internal washing;
- After the pump has stopped, it is necessary to drain the toxic or harmful liquids and perform the internal washing before performing repair or maintenance operations.

- 5.2.1 Only act on the air supply to stop the pump normally: close the control valve, the 3-way valve **and discharge the residual pressure of the pump pneumatic system.**



CAUTION risk of stalling, premature wear/breakage of the diaphragms.

Never stop the pump (when it is running and/or when the pneumatic circuit is under pressure) by closing the product circuit suction valves, to avoid premature wear and/or breakage of the diaphragms and residual pressures in the pneumatic circuit inside the pump.

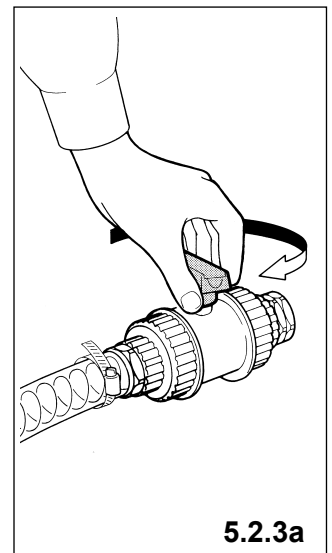
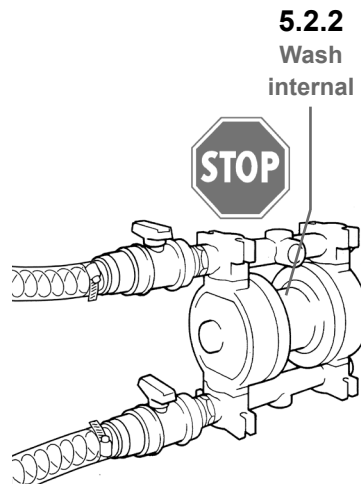
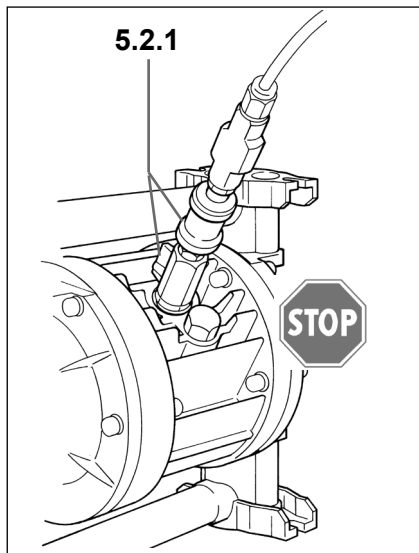

- 5.2.2 MA-MP pumps are not self-draining, therefore, if fluids are used that crystallise, it is always necessary to wash the inside with suitable liquid immediately after the stop.



CAUTION: risk of damaging the pump.

The prolonged shutdown of the pump containing fluids that crystallise, can cause the valves and diaphragms to stick and the subsequent malfunction.

- 5.2.3 If the stop is definitive and prolonged, it is necessary to:

- 7.2.4a If necessary, the product valves can be closed only after having stopped the pump pneumatically.

- 5.2.4 After the first two hours of operation and after stopping the pump correctly, check that all of the pump bolts are tight.



CAUTION: risk of internal back-pressures and projection of components during disassembly.

In severe conditions (incorrect installations and/or stops and/or in stall conditions), residual pressures inside the pump can be generated which are not discharged. Before opening and disassembling the pump, it is necessary to secure the pump casings with a suitable ratchet strap and wear suitable Personal Protective Equipment (PPE).

Pump stop is thus completed.

5.3 EMERGENCY STOP OF THE PUMP



In conditions of detected danger and/or malfunction of the pump, it is necessary to promptly stop in emergency conditions proceeding as follows.

Requirements after stopping the pump

- After stopping in emergency conditions, definitively resolve the dangerous situation before restarting the pump;
- After stopping the pump, the liquids that crystallise must be discharged and the inside of the pump must be washed immediately after stopping;
- If the liquid to be processed is changed after the pump has stopped, it is necessary to perform draining and the internal washing;
- After the pump has stopped, it is necessary to drain the toxic or harmful liquids and perform the internal washing before performing repair or maintenance operations.

- 5.3.1 To stop the pump in emergency conditions, only act on the compressed air supply. Readily operate on the 3-way sectioning valve (from a protected position upstream of the supply circuit) for the EMERGENCY stop command.

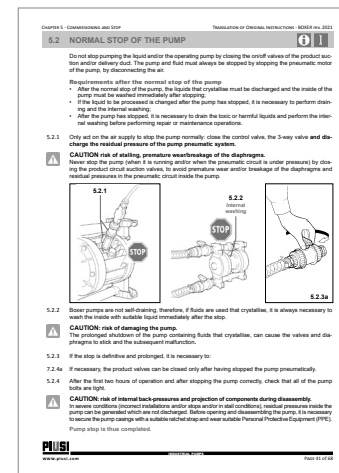
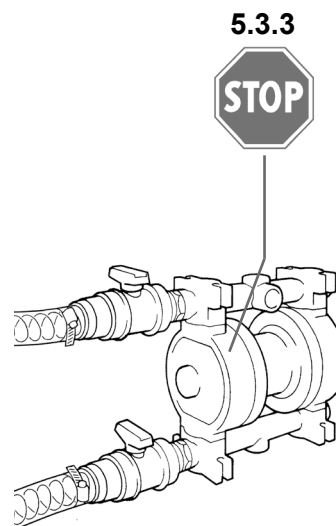
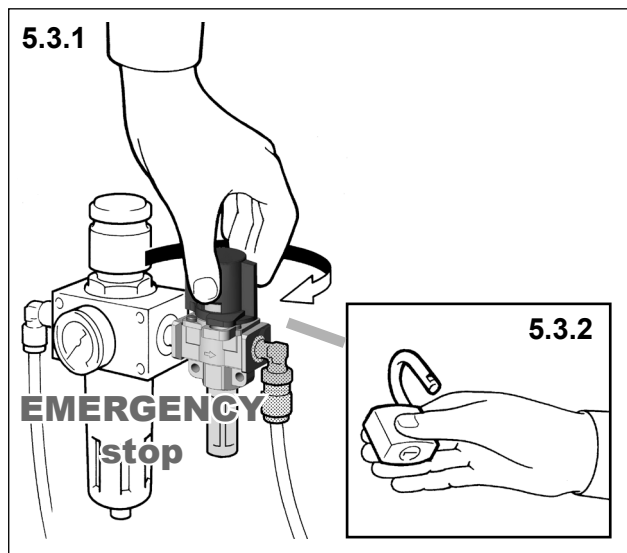

- CAUTION** risk of stalling, premature wear/breakage of the diaphragms.
Never stop the pump (when it is running and/or when the pneumatic circuit is under pressure) by closing the product circuit suction valves, to avoid premature wear and/or breakage of the diaphragms and residual pressures in the pneumatic circuit inside the pump.

- 5.3.2 Interlock the 3-way safety valve of the compressed air supply before operating.

- 5.3.3 Definitively resolve the dangerous condition before restoring the compressed air supply to the pump.

- 5.3.4 If the stop is prolonged and/or definitive, it is necessary to operate as described in *Section 5.2 NORMAL STOP OF THE PUMP*.

Stopping the pump in emergency conditions is thus completed.

This chapter contains the maintenance timetable or the operations foreseen by the Manufacturer in order to ensure a safe and long-lasting maintenance of the MA-MP pumps.

THIS PART INCLUDES THE FOLLOWING TITLES		PAGE
6.1	SCHEDULED MAINTENANCE TABLE	40
6.2	EXTERNAL CLEANING AND TIGHTNESS CHECK	41
6.3	TIGHTNESS CHECK	43
6.4	PRODUCT CIRCUIT MAINTENANCE	45
6.5	AIR CIRCUIT MAINTENANCE	50

Below is a description of how to behave in each of the phases listed above.

6.1 SCHEDULED MAINTENANCE TABLE



The scheduled maintenance operations are reserved for qualified and authorised Mechanical Servicemen, equipped with suitable Personal Protective Equipment (PPE), who know and comply with the contents of this Manual.

To ensure optimal performance and safe use of the pump, it is necessary to periodically perform the routine maintenance operations indicated in the following table and dealt with in the following sections.

The timing of the reported operations refers to use under normal conditions; for harsh installations and operating conditions, the indicated ranges must be downgraded accordingly.

SEC.	SCHEDULED MAINTENANCE	every 500 hours	500.000 cycles	10.000.000 cycles	20.000.000 cycles
6.2	EXTERNAL CLEANING AND TIGHTNESS CHECK:		check	check	replacement
6.2.1	• External cleaning of the Pump	✓	--	--	--
6.2.2	• Product Circuit Tightness Check	✓	--	--	--
6.3	TIGHTNESS CHECK		check	check	replacement
6.3.1	• Tightness check	--	✓	--	--
6.3.2	• Tightening torque table	--	--	--	--
6.4	PRODUCT CIRCUIT MAINTENANCE:			check	replacement
6.4.1	• Pump Disassembly	--	--	✓	✓
6.4.2	• Internal cleaning of the product circuit	--	--	✓	✓
6.4.3	• Check and/or replacement of valves	--	--	✓	✓
6.4.4	• Check and/or replacement of diaphragms	--	--	✓	✓
6.4.5	• Pump Re-assembly	--	--	✓	✓
6.5	AIR CIRCUIT MAINTENANCE				
6.5.1	• Pump Disassembly		When necessary		
6.5.2	• MA-MP Coaxial Exchanger Replacement		50.000.000 cycles		
6.5.3	• Pump Re-assembly		When necessary		



CAUTION

In the presence of heavy uses (concentrated corrosive liquids or liquids that crystallise), it is necessary to increase the frequency of operations.



CAUTION: risk of internal back-pressures and projection of components during disassembly.

In severe conditions (incorrect installations and/or stops and/or in stall conditions), residual pressures inside the pump can be generated which are not discharged. Before opening and disassembling the pump, it is necessary to secure the pump casings with a suitable ratchet strap and wear suitable Personal Protective Equipment (PPE).

6.2 EXTERNAL CLEANING AND TIGHTNESS CHECK



This operation is reserved for trained and qualified Mechanical Servicemen, equipped with suitable Personal Protective Equipment (PPE); see the Technical and Safety Data Sheets of the treated liquid.



CAUTION: risk of contact with toxic or corrosive fluids.

The external cleaning and tightness check of the suction and delivery circuit of the pump must be carried out periodically following the procedures described below.

6.2.1 EXTERNAL CLEANING OF THE PUMP

The pump must be cleaned externally periodically every 500 hours of operation to allow visual inspections and safe operations. The presence of dust and/or deposits on the external surfaces of the pump can negatively affect process temperatures. In environments with a potentially explosive atmosphere, it can even compromise the safety envisaged by the marking.



CAUTION: risk of overheating and, in environments with a potentially explosive atmosphere, risk of fire/explosion.

In environments with a potentially explosive atmosphere, it can even compromise safety, causing overheating and/or flammability of the dust.

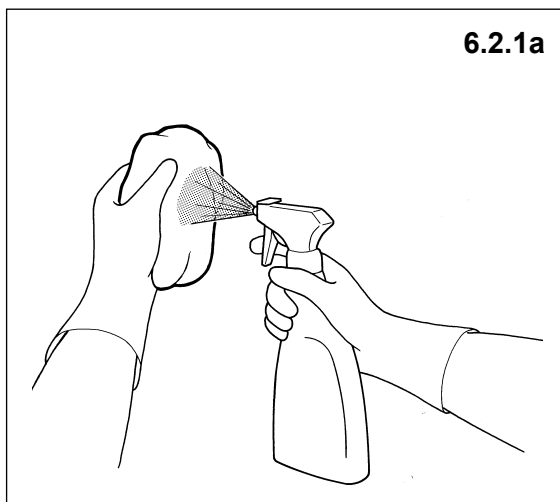

6.2.1a



6.2.1c

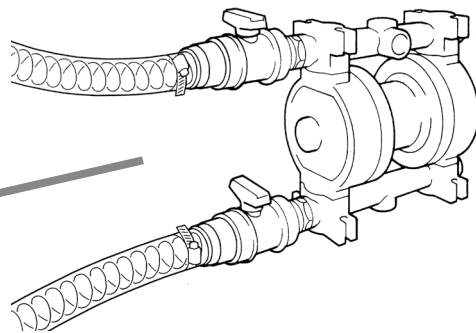

Safety requirements before starting the operation:

- Pump stopped with air supply disconnected and interlocked and residual pressure discharged;
- Closed suction and delivery valves;
- Suction and delivery pump and circuits cooled.

Proceed as follows to clean the outside of the pump:

- 6.2.1a Remove dust deposits from the external surfaces of the pump using a disposable cloth dampened with a suitable neutral detergent.



CAUTION: risk of damage and/or fire.

Do not use detergents that are not compatible with the construction materials of the pump, solvents or flammable substances.

- 6.2.1b Remove dust deposits from the external surfaces of the suction and delivery pipes near the pump using disposable cloths dampened with a suitable detergent (compatible with the construction materials of the pump).

- 6.2.1c Check that the residual risk warning labels are clearly visible and legible; otherwise, replace them. Remove any tools and cloths used from the pump.

The external cleaning of the pump is completed.

6.2.2 PRODUCT CIRCUIT TIGHTNESS CHECK

The seal of the product circuit of the pump must be checked after the first 2 hours of operation and then periodically every 500 hours, working as follows:



CAUTION: risk of contact with toxic or corrosive fluids and/or ejection of pressurised fluid.

Before operating near the pump, it is necessary to wear suitable Personal Protective Equipment (PPE); (see the *Technical and Safety Data Sheets of the treated liquid*).

Safety requirements for the tightness check:

- Pump stopped with air supply disconnected and interlocked and residual pressure discharged;
- Pump with the external surfaces clean;
- Open product sectioning valves (suction and delivery);
- Overflown pump.

SUCTION SEAL CHECK

The suction seal of the pump must be checked with the pump running, operating as follows:

- 6.2.2a Visually check for leaks on the suction circuit and on the pump;
- 6.2.2b If leaks are detected, immediately stop the pump, disconnect the air supply and discharge the residual pressure from the internal pneumatic circuit.
- 6.2.2c If leaks are detected, check the tightening of the fastening parts that are part of the suction circuit (hose connection, clamps, fittings) and/or of the screws of the pump casing and manifold.

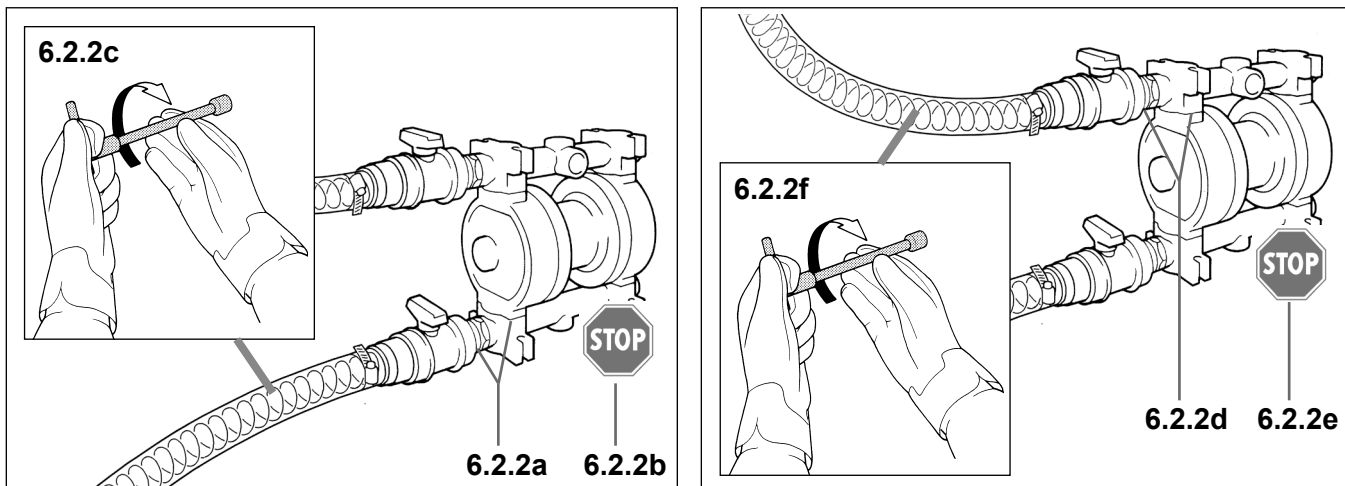

CAUTION: risk of product leakage.

The tightness check ensures a correct seal of the product circuit; in the event of leaks or product leaks, it is always necessary to carefully check that the pump and the internal sealing components are intact before commissioning.

The check of the hydraulic seal of the product suction circuit is completed.

DELIVERY SEAL CHECK

The pressurised check must be carried out with the pump running, operating as follows:

- 6.2.2d Visually check for leaks on the delivery circuit and on the pump.
- 6.2.2e If leaks are detected, immediately stop the pump, disconnect the air supply and discharge the residual pressure from the internal pneumatic circuit.
- 6.2.2f Tighten the parts involved on the delivery (hose connection, clamps, fittings) and/or the screws of the pump casing and manifold as described in *Section 6.3 TIGHTNESS CHECK*.



CAUTION: risk of product leakage.

The tightness check ensures a correct seal of the product circuit; in the event of leaks or product leaks, it is always necessary to carefully check that the pump and the internal sealing components are intact before commissioning.

The check of the hydraulic seal of the product delivery circuit is completed.

6.3 TIGHTNESS CHECK



This operation is reserved for trained and qualified Mechanical Servicemen, equipped with suitable Personal Protective Equipment (PPE); see the Technical and Safety Data Sheets of the treated liquid.



CAUTION: risk of contact with toxic or corrosive fluids.

6.3.1 TIGHTNESS CHECK

The tightness of the pump and product ducts must be checked after the first 2 hours of operation and then periodically every 500,000 cycles of operation.



CAUTION: risk of product leakage.

The tightness check ensures a correct seal of the product circuit; in the event of leaks or product leaks, it is always necessary to carefully check that the pump and the internal sealing components are intact before commissioning.

Safety requirements for the operation:

- Pump stopped with air supply disconnected and interlocked and residual pressure discharged;
- Closed suction and delivery valves;
- Pump with the external parts cleaned/washed;
- Suction and delivery pump and circuits at MAX ambient temperature 40°C.

Proceed as follows to check the tightness of the pump:

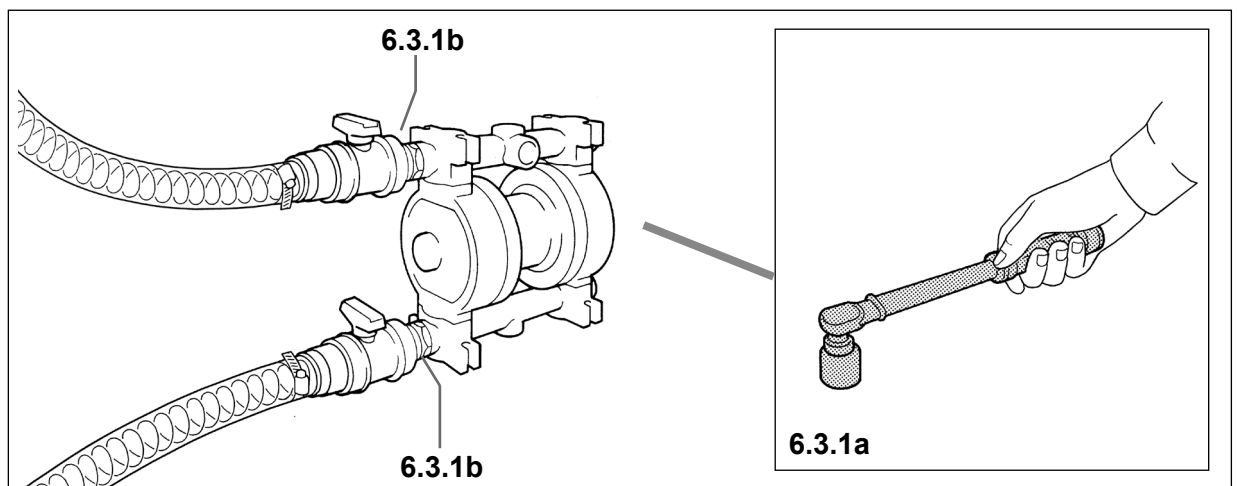

- 6.3.1a Using a suitable torque wrench, check the tightness of the pump screws respecting the torques indicated in the *TIGHTENING TORQUE TABLE* on page 48.



CAUTION: risk of stress corrosion cracking phenomena and sudden breakages.

Excessive tightening (especially on plastic pumps), can cause dangerous tensions on some components and sudden breakages that cannot be attributed to construction defects.

- 6.3.1b Check the tightness of the connection fittings to the pump and the tightness of the hose clamps of the product ducts.
- 6.3.1c Remove the tools used from the pump.

The tightness check of the pump and product ducts is completed.

6.3.2 TIGHTENING TORQUE TABLE

The following table shows the tightening torques referred to the construction components and their materials. Tightening must be carried out respecting the tightening torques indicated by the Manufacturer and expressed in Nm (newton meter), with reference to each model and construction material.



CAUTION: risk of stress corrosion cracking phenomena and sudden breakages.

Excessive tightening (especially on plastic pumps) can cause dangerous tensions on some components and sudden breakages that cannot be attributed to construction defects.

PUMP	Material	MAIN BLOCK	PUMP CASING	MANIFOLD		CAP		PLUG	
				OR-PTFE	OR-NBR	1 M	2 M	OR-PTFE	OR-RUBBER
MA-MP 130	PP	--	5 Nm	6 Nm	8 Nm	27 Nm	30 Nm	18 Nm	18 Nm
	AL	--	6 Nm	7 Nm	7 Nm	27 Nm	30 Nm	20 Nm	20 Nm
MA-MP 140	PP	--	8 Nm	8 Nm		30 Nm	33 Nm	30 Nm	
	AL	--	8 Nm	8 Nm		30 Nm	33 Nm	30 Nm	
MA-MP 180	PP	--	8 Nm	10 Nm	8 Nm	33 Nm		33 Nm	
	AL	--	5 Nm	7 Nm	7 Nm	33 Nm		33 Nm	
MA-MP 190	PP	--	8 Nm	8 Nm	10 Nm	37 Nm	40 Nm	40 Nm	
	AL	--	10 Nm	15 Nm	15 Nm	37 Nm	40 Nm	40 Nm	

6.4 PRODUCT CIRCUIT MAINTENANCE



This operation is reserved for trained and qualified Mechanical Servicemen, equipped with suitable Personal Protective Equipment (PPE); see the Technical and Safety Data Sheets of the treated liquid.



CAUTION: risk of contact with toxic or corrosive fluids.

The maintenance of the product circuit of the pump must be carried out periodically to ensure an optimal performance and the necessary safety conditions, operating as described below.

6.4.1 PUMP DISASSEMBLY

To carry out the product circuit maintenance, it is necessary to disassemble the pump as follows:

Safety requirements for the operation:

- Pump stopped with air supply disconnected and interlocked and residual pressure discharged;
- Pump with the external parts cleaned/washed;
- Pump with internal product circuit washed and decontaminated (according to the pumped liquid);
- Pump with product circuit drained of the contaminated washing liquid;
- Closed product sectioning valves (suction and delivery);
- Suction and delivery pump and circuits at ambient temperature.

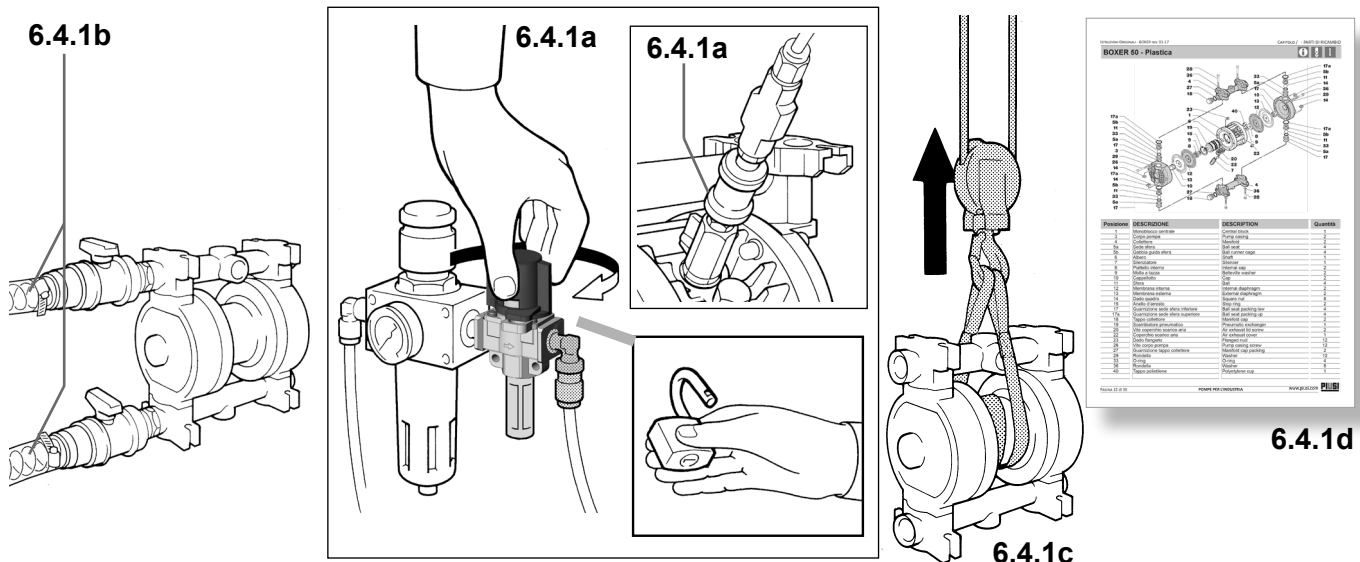

- 6.4.1a To stop the pump, only operate on the air supply: close the ball valve and the 3-way sectioning valve. Close the upstream 3-way safety valve, **discharge the residual pressure from the pneumatic system of the pump and place the safety interlock.**



CAUTION: risk of internal back-pressures and projection of components during disassembly.

In severe conditions (incorrect installations and/or stops and/or in stall conditions), residual pressures inside the pump can be generated which are not discharged. Before opening and disassembling the pump, it is necessary to secure the pump casings with a suitable ratchet strap and wear suitable Personal Protective Equipment (PPE).

- 6.4.1b Disconnect the suction and delivery pipes of the pump fluid.
- 6.4.1c Disassemble and remove the pump from the place of installation using suitable lifting equipment and adequately drain the product circuit according to the treated product.



CAUTION: risk of leakage of the washing and/or contaminated liquid.

The pump is not self-draining, pay attention during handling and disassembly.

- 6.4.1d Use the relevant Spare Parts table for the pump disassembly and reassembly sequence to access the internal parts of the treated operations.

6.4.2 INTERNAL CLEANING OF THE PRODUCT CIRCUIT

The pump must be internally cleaned periodically every 20.000.000 cycles of operation to allow visual inspections and a safe use of the pump. The presence of dust and/or deposits on the external surfaces of the pump can negatively affect process temperatures. In environments with a potentially explosive atmosphere, it can even compromise the safety.

CAUTION: risk of overheating and, in environments with a potentially explosive atmosphere, risk of fire. In environments with a potentially explosive atmosphere, the presence of dust can even compromise the safety.

Safety requirements for the operation:

- Disassembled pump;
- Pump with the external parts cleaned/washed;
- Pump with internal product circuit washed and decontaminated (according to the pumped liquid).
- Pump with product circuit drained of the contaminated washing liquid.

Proceed as follows to clean the inside of the product circuit of the pump:

6.4.2a Disassemble the suction and delivery manifolds by removing the fastening elements.

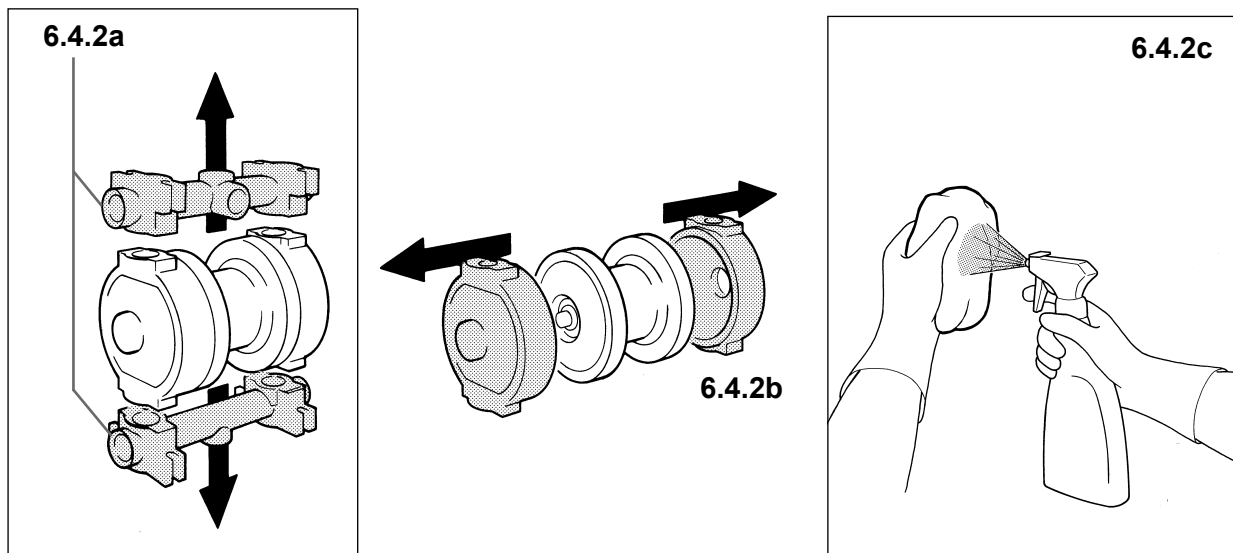

CAUTION: risk of internal back-pressures and projection of components during disassembly. In severe conditions (incorrect installations and/or stops and/or in stall conditions), residual pressures inside the pump can be generated which are not discharged. Before opening and disassembling the pump, it is necessary to secure the pump casings with a suitable ratchet strap and wear suitable Personal Protective Equipment (PPE).

6.4.2b Disassemble the fixing screws and remove the pump casings.

6.4.2c Check for solid deposits inside the pump and, if present, remove them and clean the internal surfaces of the pump using a disposable cloth dampened with detergent (suitable for the treated product) and compatible with the construction materials of the pump and with the work environment.

CAUTION: risk of damage and/or fire. Do not use detergents that are not compatible with the construction materials of the pump, solvents or flammable substances.

6.4.2d Visually inspect the internal surfaces in contact with the product and make sure that there are no abrasions, corrosion, cracks and/or damages to the components.

The internal cleaning of the product circuit of the pump is completed.

6.4.3 CHECK AND/OR REPLACEMENT OF VALVES (Suction and Delivery)

The suction and delivery valves (ball and ball seats) are components subject to wear. Their duration is strongly affected by the conditions of use and by the chemical and physical stresses. The suction and delivery valves must be periodically checked every 10,000,000 cycles of operation, to ensure correct operation of the product seals and the best performance of the pump.

Safety requirements before starting the operation:

- Pump removed from the workstation and residual pressure inside the air circuit discharged;
- Pump with the external parts cleaned/washed;
- Pump with internal product circuit washed and decontaminated (according to the pumped liquid).
- Pump with product circuit drained of the contaminated washing liquid.

Proceed as follows to check and/or replace the pump valves:

6.4.3a Disassemble the suction and delivery manifolds by removing the fastening elements.

6.4.3b Remove the seats and the balls of the delivery and suction valves and clean them with a cloth dampened with suitable detergent and/or replace them with Original Spare Parts of the same type and material.

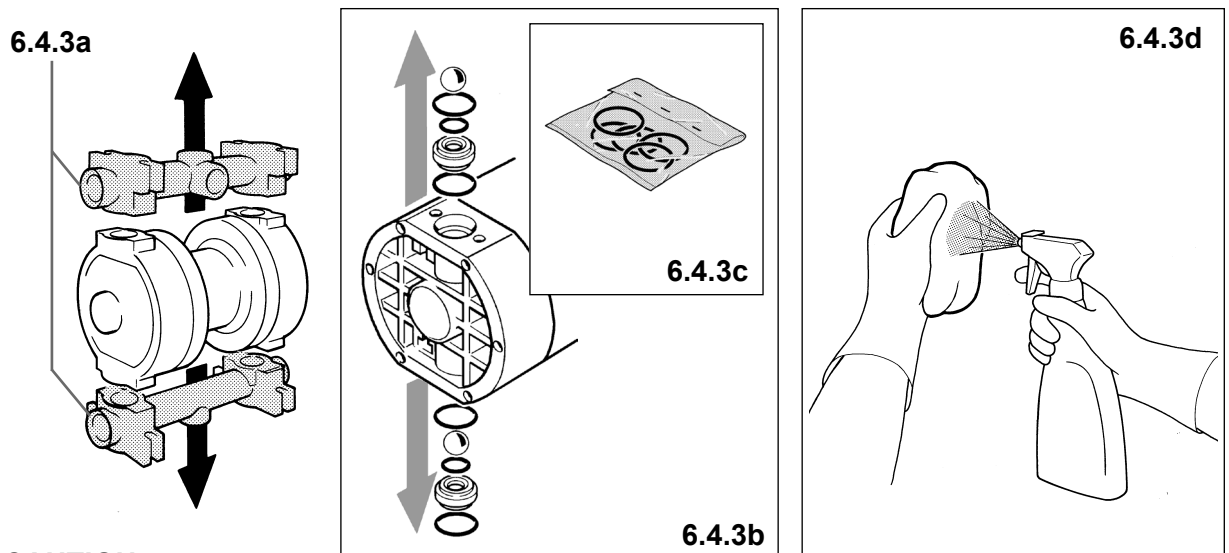

CAUTION: risk of damage and/or fire.

Do not use detergents that are not compatible with the construction materials of the pump, solvents or flammable substances.

6.4.3c Check the condition of the gaskets and, if necessary, replace with Original Spare Parts of the same type and material.

6.4.3d Check that there are no solid deposits inside the valves, otherwise remove them with a disposable clean cloth dampened with detergent (suitable for the treated product).

The check and/or replacement of the pump valves is completed.

6.4.4 CHECK AND/OR REPLACEMENT OF DIAPHRAGMS (End of Life)

The diaphragms (internal and in contact with the product) are components subject to wear. Their duration is strongly affected by the conditions of use and by the chemical and physical stresses. From tests carried out on thousands of installed pumps (with head equal to 0.5 m at 20°C), it was found that the normal duration exceeds 100,000,000 (one hundred million) cycles.



CAUTION: For safety reasons, in environments with a potentially explosive atmosphere, the pump diaphragms must be disassembled and checked **every 10,000,000 (ten million) cycles** and **preventively replaced every 20,000,000 (twenty million) cycles**.

MANDATORY OPERATIONS	SCHEDULING OF OPERATIONS		
	every 500 hours	CHECK every 10.000.00 cycles	REPLACEMENT every 20.000.00 cycles
INTERNAL CLEANING AND CHECK	✓	--	--
DIAPHRAGM CHECK	--	✓	--
DIAPHRAGM REPLACEMENT	--	--	✓

Safety requirements before starting the operation:

- Pump removed from the workstation and residual pressure inside the air circuit discharged;
- Pump with the external parts cleaned/washed;
- Pump with internal product circuit washed and decontaminated (according to the pumped liquid).
- Pump with product circuit drained of the contaminated washing liquid.

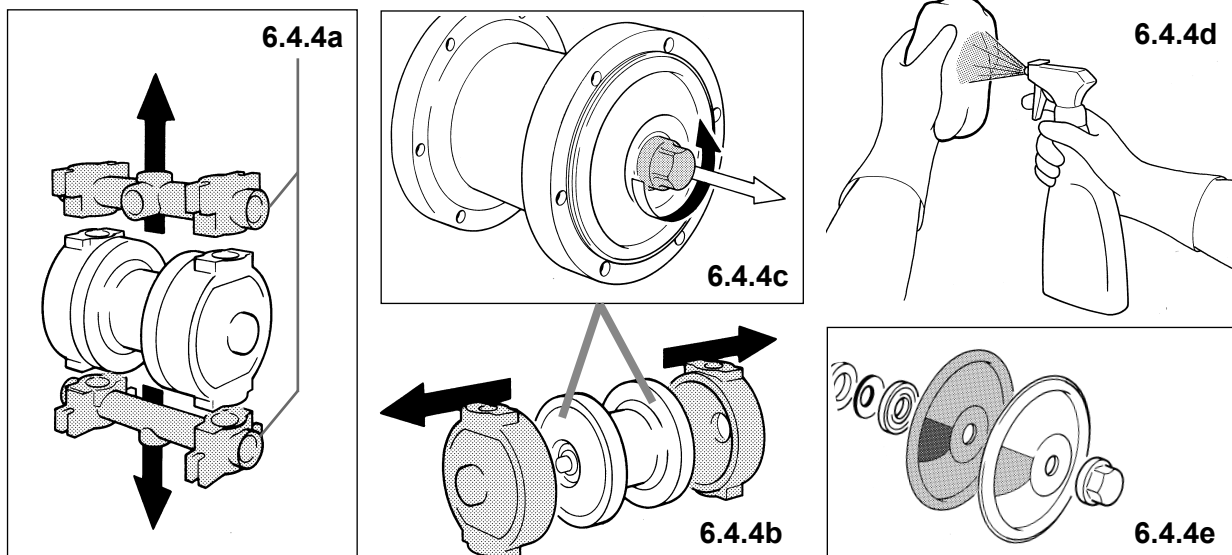

6.4.4a Disassemble the suction and delivery manifolds by removing the fastening elements.



CAUTION: risk of internal back-pressures and projection of components during disassembly.

In severe conditions (incorrect installations and/or stops and/or in stall conditions), residual pressures inside the pump can be generated which are not discharged. Before opening and disassembling the pump, it is necessary to secure the pump casings with a suitable ratchet strap and wear suitable Personal Protective Equipment (PPE).

6.4.4b Disassemble the fixing screws and remove the pump casings.

6.4.4c Remove the diaphragm locking cap of both circuits.

6.4.4d Check that there are no solid deposits, otherwise remove them with a disposable clean cloth dampened with a detergent suitable for the treated product, clean the diaphragms.



CAUTION: risk of damage and/or fire.

Do not use detergents that are not compatible with the construction materials of the pump, solvents and/or flammable substances.

6.4.4e Remove the diaphragms from both sides of the pump.

- 6.4.4f Check the condition of the diaphragms and that there are no yield points, cracks or breaking points. Based on the outcome of the performed checks and the timing provided for the replacement of the diaphragms, establish whether to reuse them and/or replace them with Original Spare Parts of the same type and material.



CAUTION: risk of fluid leakage.

Do not use the pump with the diaphragms compromised, damaged or of a different type and material to the original (reported on the Composition Code), or that have reached their “End of Life” as indicated by the Manufacturer.

The replacement of the pump diaphragms is completed.

6.4.5 PUMP RE-ASSEMBLY

To reassemble the pump after internally cleaning and checking and/or replacing the valves and diaphragms proceed as follows:

- 6.4.5a Check the condition of the pump pressure static seal O-ring gaskets (they must not be dry, deformed or crushed); otherwise, replace them with Original Spare Parts.

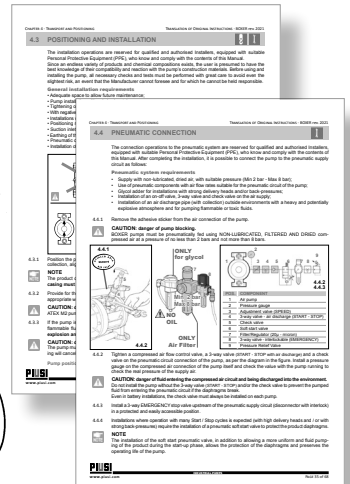
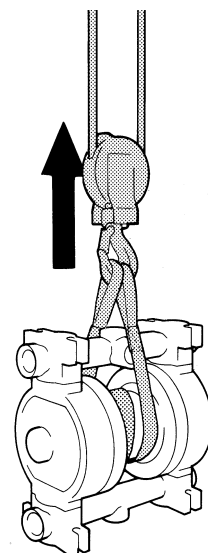
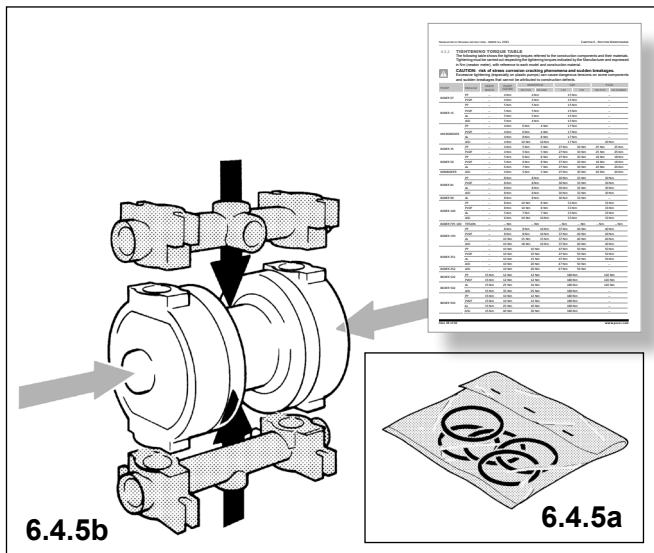

NOTE

The PTFE static seal O-rings must be mandatorily replaced after every disassembly.

- 6.4.5b Re-assemble the pump by repeating the previously described sequence in reverse order and perform a progressive and uniform tightening of the fixing bolts respecting the tightening torques indicated by the Manufacturer (see 6.3.2 TIGHTENING TORQUE TABLE on page 48).



CAUTION: risk of stress corrosion cracking phenomena and sudden breakages.

Excessive tightening (especially on plastic pumps) can cause dangerous tensions on some components and sudden breakages that cannot be attributed to construction defects.

- 6.4.5c Reposition and connect the pump to the system and pneumatic supply circuit as described in Sections 4.3 and 4.4.

The maintenance of the product circuit of the pump is completed.

6.5 AIR CIRCUIT maintenance



This operation is reserved for trained and qualified Mechanical Servicemen, equipped with suitable Personal Protective Equipment (PPE); see the Technical and Safety Data Sheets of the treated liquid.



CAUTION: risk of contact with toxic or corrosive fluids.

The air circuit maintenance involves the replacement of the pneumatic exchanger, which is necessary in exceptional cases due to incorrect installations in very dusty environments, in the presence of saturated vapours that can damage the internal circuit or, if following the breakage of the diaphragms, the corrosive fluid has entered the pneumatic circuit.



CAUTION: danger of damage to the internal pneumatic circuit.

For installations with the pump in environments with a heavy atmosphere (dusts, vapours or saturated vapours), it is necessary to install a pipe and fittings (of suitable materials) to bring the air discharge point outside the operating environment.

Safety requirements before starting the operation:

- Pump stopped with air supply disconnected and interlocked and residual pressure discharged;
- Pump with the external parts cleaned/washed;
- Pump with internal product circuit washed and decontaminated (according to the pumped liquid);
- Pump with product circuit drained of the contaminated washing liquid.
- Closed product sectioning valves (suction and delivery);
- Suction and delivery pump and circuits cooled.

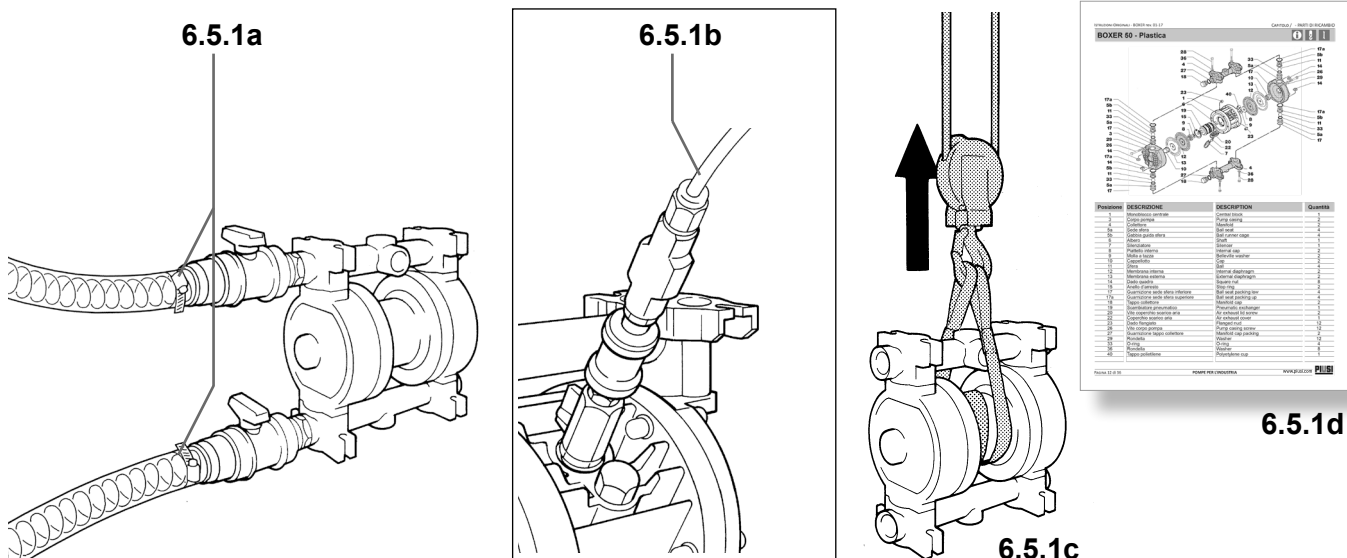

6.5.1 PUMP DISASSEMBLY

To replace the pneumatic exchanger of the air circuit it is necessary to disassemble the pump as follows:

- 6.5.1a Disconnect the suction and delivery pipes of the pump fluid.
- 6.5.1b Disconnect the compressed air supply pipe from the pump.
- 6.5.1c Remove the pump from the place of installation using suitable lifting and disassembly equipment.



CAUTION: risk of contaminated liquid leaking; risk of injuries and/or harm to health.

The pump is not self-draining, pay attention during disassembly and handling. Should the pump be returned to the Manufacturer or to an Authorised Assistance Center, it must first be emptied of the product or any detergents. If toxic, noxious or other types of health harming products have been used, the pump must be suitably treated and washed before it is sent.

- 6.5.1d Use the relevant Spare Parts table for the pump disassembly and reassembly sequence to access the internal parts of the treated operations.

6.5.2 COAXIAL PNEUMATIC EXCHANGER REPLACEMENT for MA-MP

All MA-MP pumps house an orthogonal pneumatic exchanger; proceed as follows to replace the pneumatic exchanger:



CAUTION: risk of contamination, injuries and/or harm to health.

Should the pump be returned to the Manufacturer or to an Authorised Assistance Center, it must first be emptied of the product or any detergents.

If toxic, noxious or other types of health harming products have been used, the pump must be suitably treated and washed before it is sent.

Safety requirements for the operation:

- Pump removed from the workstation and residual pressure inside the air circuit discharged;
- Pump with the external parts cleaned/washed;
- Pump with internal product circuit washed and decontaminated (according to the pumped liquid).
- Pump with product circuit drained of the contaminated washing liquid.

6.5.2a Disassemble the suction and delivery manifolds by removing the fastening elements.

6.5.2b Disassemble the fixing screws and remove the pump casings.

6.5.2c Remove the diaphragm locking cap of both circuits and remove the pump diaphragms.

6.5.2d Disassemble the coaxial pneumatic exchanger by removing the fastening elements.

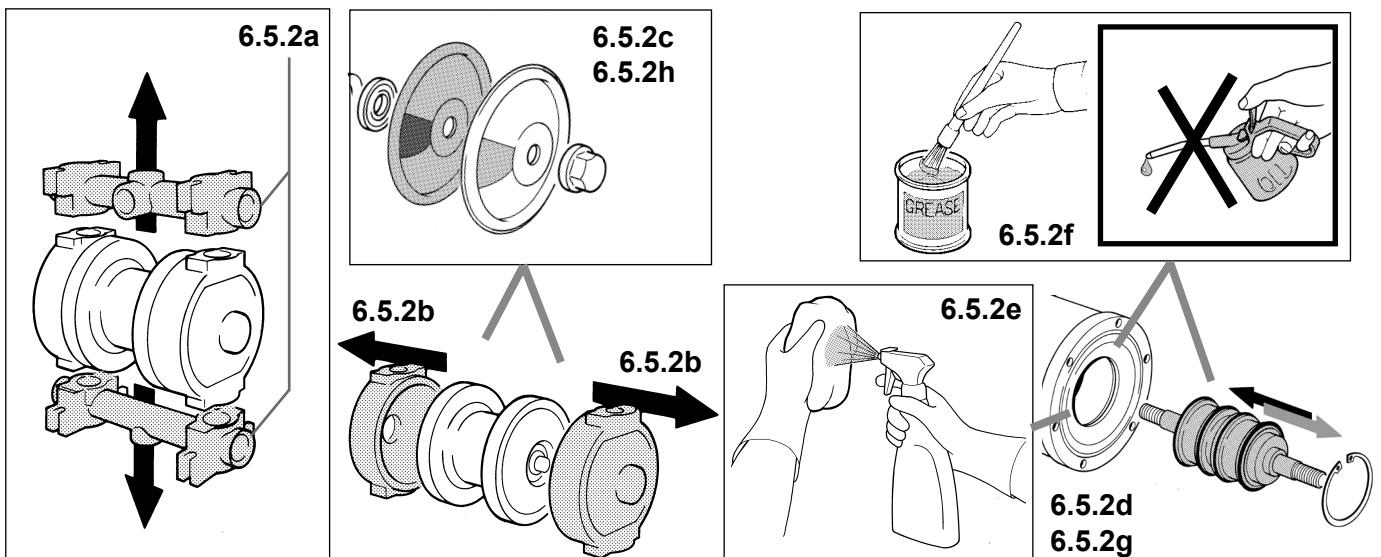

6.5.2e Clean the central and the diaphragms using a disposable clean cloth dampened with a suitable detergent (for the construction material of the pump and the treated product).



CAUTION: risk of damage and/or fire.

Do not use detergents that are not compatible with the construction materials of the pump, solvents or flammable substances.

6.5.2f Apply a thin layer of suitable grease (MOLYKOTE[®]) on the holes of the central (bushing hole and shuttle hole).



CAUTION: danger of pump blocking.

Do not use any type of oil; the oil removes the grease and once discharged, it causes consequent blockage due to lack of lubrication.

6.5.2g Replace the exchanger and the connection shaft with an Original Spare Part having the same characteristics (construction materials of the components).



CAUTION: risk of malfunctioning and blocking of the pump.

The pneumatic exchanger must not be opened to avoid incorrect reassembly and consequent malfunction of the pump.

6.5.2h Reassemble the diaphragms and tighten the relative fixing cap.

The replacement of the coaxial pneumatic exchanger for MA-MP pumps is completed.

6.5.3 PUMP RE-ASSEMBLY

After replacing the pneumatic exchanger, reassemble the pump as follows:

- 6.5.3a Check the condition of the pump pressure static seal O-ring gaskets (they must not be dry, deformed or crushed); otherwise, replace them with Original Spare Parts.



NOTE

The PTFE static seal O-rings must be mandatorily replaced after every disassembly.

- 6.5.3b Re-assemble the pump by repeating the previously described sequence in reverse order and perform a progressive and uniform tightening of the fixing bolts respecting the tightening torques indicated by the Manufacturer (see 6.3.2 TIGHTENING TORQUE TABLE on page 48).



CAUTION: risk of stress corrosion cracking phenomena and sudden breakages.

Excessive tightening (especially on plastic pumps) can cause dangerous tensions on some components and sudden breakages that cannot be attributed to construction defects.

- 6.5.3c Reposition and connect the pump to the system and pneumatic supply circuit as described in Sections 4.4 and 4.5.

The replacement of the pneumatic exchanger and the reassembly of the pump is completed.

The following instructions are intended exclusively for authorised skilled Maintenance Engineers who know and comply with the contents of the Original Instructions. In the event of abnormal behaviour and in order to fix faults, please refer to the following troubleshooting instructions. The graphic setting is in table format with direct correspondence between Anomaly, Possible Cause and Suggestion.



NOTE

For more serious problems, we strongly recommend that you contact the PIUSI SERVICE DEPARTMENT or an Authorised Assistance Center; our Engineers will provide you with assistance as quickly as possible.



CAUTION

Before performing any operation and accessing the pump, it is necessary to:

- disconnect and interlock the compressed air and discharge the residual pressure from the pneumatic circuit inside the pump;
- disconnect the product on/off valves (suction and delivery);
- if necessary, clean the outside of the pump;
- if necessary, wash (decontaminate) the product circuit inside the pump.



CAUTION: risk of internal back-pressures and projection of components during disassembly.

In severe conditions (incorrect installations and/or stops and/or in stall conditions), residual pressures inside the pump can be generated which are not discharged. Before opening and disassembling the pump, it is necessary to secure the pump casings with a suitable ratchet strap and wear suitable Personal Protective Equipment (PPE).

ANOMALY	POSSIBLE SOURCE	ADVICE
1 The pump does not start.	1.1 No air in the circuit.	1.1a Check circuit, valves and connections.
	1.2 Insufficient air pressure.	1.2a Adjust pressure on the relevant reducer.
	1.3 Insufficient air flow rate.	1.3a Check that piping and accessories have suitable passage.
	1.4 Damaged control valve.	1.4a Check and replace the control valve.
	1.5 Pump intake or delivery closed.	1.5a Disconnect intake and delivery hoses and check if the pump starts.
	1.6 Pneumatic exchanger damaged.	1.6a Replace exchanger; check whether the air discharge is obstructed by ice. If so, clear it (see air supply paragraph).
	1.7 Broken diaphragm.	1.7a if any air comes out from the product delivery pipe; if so, replace diaphragm.
2. The pump exchanges but does not move the fluid.	2.1 The balls do not close.	2.1a Disassemble the manifolds and clean the ball seats or replace both balls and their seats.
	2.2 Intake too high.	2.2a Reduce intake height.
	2.3 Fluid is too viscous.	2.3a Install larger piping especially on the intake side and decrease the pump cycles.
	2.4 Intake side is obstructed.	2.4a Check and clean.

Continues on the next page

Continued from the previous page

ANOMALY	POSSIBLE SOURCE	ADVICE
3. Pump functions irregularly.	3.1 Internal pneumatic exchanger is worn or faulty.	3.1a Replace pneumatic exchanger.
	3.2 Shaft is worn.	3.2a Replace pneumatic exchanger.
	3.3 Ice on discharge gate.	3.3a Dehumidify and filter air.
	3.4 Lack of air flow.	3.4a Check all air control devices, and in particular Snap-On couplings.
	3.5 Internal exchanger dirty.	3.5a Replace pneumatic exchanger.
4. Pump cycles are slow.	4.1 Fluid is too viscous.	4.1a No remedy.
	4.2 Delivery hose is obstructed.	4.2a Check and clean.
	4.3 Intake is obstructed.	4.3a Check and clean.
5. The pump does not exchange.	5.1 Intake obstructs during operation.	5.1a Replace intake hose.
	5.2 Dirty air, containing condensation or oil.	5.2a Check air line.
	5.3 Insufficient air flow or pressure	5.3a Check pressure using a pressure gauge installed on the pump when it is running: <i>see fig.4.4.3</i> . If pressure at that point is too low in relation to the network pressure, check all air especially snap-on ones. Check if all air control devices have sufficient flow rate. CAUTION: in 90% of cases, stall occurrences are caused by snap-on fittings.
	5.4 Faulty distributor.	5.4a Replace the distributor.
	5.5 Stop procedure not complied with.	5.5a Comply with stop procedure, see <i>Section 5.2</i>
6. Pump does not distribute delivery value stated on table.	6.1 Product intake hose is badly connected.	6.1a Check and reconnect.
	6.2 Piping is clogged.	6.2a Check and clean.
	6.3 Fluid is too viscous.	6.3a Install larger piping especially on the intake side and decrease pump cycles.
	6.4 Balls do not close.	6.4a Disassemble the manifolds and clean the seats or replace the balls and their seats.
	6.5 Insufficient air flow.	6.5a Check pressure using a pressure gauge installed on the pump when it is running: <i>see fig.4.4.3</i> . If pressure at that point is too low in relation to the network pressure, check all air especially snap-on ones. Check if all air control devices have sufficient flow rate. CAUTION: in 90% of cases, stall occurrences are caused by snap-on fittings.
	6.6 Probable pressure losses on the air supply line to the pump.	6.6a Check the pressure at the pump inlet. Eliminate pressure losses on the compressed air supply line to the pump.
	6.7 Probable back-pressures or heads higher than those allowed by the Model of the pump used in relation to the delivered flow rate.	6.7a Check the actual product pressure distributed by the outlet pump to the delivery manifold. Eliminate back-pressures on the product delivery line or use the Pump model suitable for the desired flow rate.

DECOMMISSIONING AND DISPOSAL

TRANSLATION OF ORIGINAL INSTRUCTIONS M0332 EN_00

PIUSI

CHAPTER 8

This chapter deals with the operations envisaged by the Manufacturer to decommission and dispose of the MA-MP pumps at the end of their life.

THIS PART INCLUDES THE FOLLOWING TITLES		PAGE
8.1	DECOMMISSIONING AND WASHING FORM	56
8.2	DISPOSAL	58

Below is a description of how to behave in each of the phases listed above.

8.1 DECOMMISSIONING AND WASHING FORM



This operation is reserved for trained and qualified Mechanical Servicemen, equipped with suitable Personal Protective Equipment (PPE); see the Technical and Safety Data Sheets of the treated liquid.



CAUTION: risk of contact with toxic or corrosive fluids.

Should the pump remain inactive for long periods or if there are leaks or malfunctions that can affect the safety of the pump or system on which it is installed, or at the “End of Life” of the diaphragms, it is necessary to decommission it until restoration of the necessary safety conditions and optimal operation of the same.



CAUTION: risk of fluid leakage, risk of fire.

Do not use the pump in compromised conditions or with the diaphragms at the “End of Life” as indicated by the Manufacturer.

8.1.1 DECOMMISSIONING DUE TO INACTIVITY

Before decommissioning for long periods of inactivity, it is necessary to proceed as follows:

- 8.1.1a Clean the external part of the pump using cloths dampened with suitable detergent (compatible with the construction materials of the pump).
- 8.1.1b Wash the inside of the pump (washing, decontamination according to the used fluid) with a suitable detergent (compatible with the construction materials).
- 8.1.1c Close the product suction and delivery on/off valves mounted on the pump.
- 8.1.1d Close the air supply using the 3-way valve and discharge the residual pressure from the pneumatic circuit inside the pump and then disconnect the air supply on the network node.



CAUTION: risk of internal back-pressures and projection of components during disassembly.

In severe conditions (incorrect installations and/or stops and/or in stall conditions), residual pressures inside the pump can be generated which are not discharged. Before opening and disassembling the pump, it is necessary to secure the pump casings with a suitable ratchet strap and wear suitable Personal Protective Equipment (PPE).

- 8.1.1e Indicate the “DECOMMISSIONING” status on the pump with a specific signal.
- 8.1.1f Should it be necessary to store the pump or send it back to the Manufacturer, proceed with the disassembly and emptying as described in *point 8.1.2 and 8.1.4*.

8.1.2 PUMP DISASSEMBLY FROM THE WORKSTATION

Proceed as following to disassemble the pump from the workstation.

Safety requirements before starting the operation:

- Pump stopped with air supply disconnected and interlocked and residual pressure discharged;
- Pump with the external parts cleaned/washed;
- Pump with internal product circuit washed and decontaminated (according to the pumped liquid);
- Pump with product circuit drained of the contaminated washing liquid.
- Closed product sectioning valves (suction and delivery);
- Suction and delivery pump and circuits at ambient temperature

- 8.1.2a Disconnect the suction and delivery pipes of the pump fluid.
- 8.1.2b Disconnect the compressed air supply pipe from the pump.
- 8.1.2c Disassemble and remove the pump from the place of installation using suitable lifting equipment and adequately drain the product circuit according to the treated product.



CAUTION: risk of leakage of the washing and/or contaminated liquid.

The pump is not self-draining, pay attention during handling and disassembly.

8.1.3 PUMP STORAGE

The pump must be stored in a suitable packaging, in a closed and protected environment at temperatures ranging from 5°C to 45°C, and a humidity level not above 90%.

MA-MP pumps are not self-draining; turn the pump upside down to completely drain the residual washing liquids from inside.

To store, proceed as described in *Section 4.1 STORAGE AND PRESERVATION*.



CAUTION: risk of contamination, injuries and/or harm to health.

Should the pump be stored or returned to the Manufacturer or to an Authorised Assistance Center, it must first be emptied of the product and/or any detergents. If toxic, noxious or other types of health harming products have been used, the pump must be suitably treated and washed and then emptied before it is stored or sent.

The pump decommissioning is completed.

8.1.4 PUMP WASHING FORM

Before sending the pump to the Manufacturer for any maintenance work or as a return, you must always carry out a thorough washing of the pump. After washing, the pump must be emptied by turning it upside down (MA-MP pumps are not self-emptying).

8.2 DISPOSAL



This operation is reserved for trained and qualified Mechanical Servicemen, equipped with suitable Personal Protective Equipment (PPE); see the *Technical and Safety Data Sheets* of the treated liquid.



CAUTION: risk of contact with toxic or corrosive fluids.

MA-MP pumps do not contain dangerous parts or that require conditioning treatments, however, they may be contaminated due to the environment of use or the type of fluid used. However, when they are worn out, they must be disposed of and demolished in the following manner:



CAUTION: risk of serious injuries, harm to health.

Do not dispose of the pump with residues of dangerous fluids or with surfaces contaminated by toxic, irritating and/or health damaging fluids.

- 8.2.1 Wash, remove or adequately decontaminate any product residues or contaminants that are dangerous to human contact and/or to the environment, working according to the instructions given in the relevant Technical Data Sheet or Safety Data Sheet of the Product used.
- 8.2.2 Wash the inside of the pump product circuit (washing, decontamination according to the used fluid) with a suitable detergent or decontaminant.
- 8.2.3 Close the product suction and delivery on/off valves of the pump.
- 8.2.3a Close the air supply using the 3-way valve and discharge the residual pressure from the pneumatic circuit inside the pump and then disconnect the air supply on the network node.
- 8.2.4 Disconnect the compressed air supply pipe from the pump.

8.2.5 PUMP DISASSEMBLY

Proceed as follows to disassemble the pump.

Safety requirements before starting the operation:

- Pump stopped with air supply disconnected and interlocked and residual pressure discharged;
 - Pump with the external parts cleaned/washed;
 - Pump with internal product circuit washed and/or decontaminated (according to the pumped liquid).
 - Closed product sectioning valves (suction and delivery);
 - Suction and delivery pump and circuits cooled.
- a. Disconnect the suction and delivery pipes of the pump fluid.
 - b. Disconnect the compressed air supply pipe from the pump.
 - c. Disassemble and remove the pump from the place of installation using suitable lifting equipment.



CAUTION: risk of leakage of the washing and/or contaminated liquid; risk of injuries

and/or harm to health. The pump is not self-draining, pay attention during handling and disassembly. If toxic, noxious or other types of health harming products have been used, the pump must be suitably treated and washed before it is stored or sent.

- 8.2.6 Separate the pump components by type and homogeneous materials (*see Section 2.2*).



CAUTION: risk of internal back-pressures and projection of components during disassembly.

In severe conditions (incorrect installations and/or stops and/or in stall conditions), residual pressures inside the pump can be generated which are not discharged. Before opening and disassembling the pump, it is necessary to secure the pump casings with a suitable ratchet strap and wear suitable Personal Protective Equipment (PPE).

- 8.2.7 For the disposal, contact Specialised Companies.



CAUTION: danger of pollution and/or accidents.

Make sure that no small or large components are dispersed in the environment which may cause pollution, accidents or direct and/or indirect damage.

The pump demolition and disposal is completed.

NOTE



A series of horizontal lines for writing notes, starting below the header bar and extending down to the footer area.

Authorised **RESELLERS**:

Authorised **ASSISTANCE CENTERS**:



RESELLER STAMP:

PIUSI

PIUSI s.p.a. - Via Pacinotti, 16/A - 46029 Suzzara (MN) ITALY
Tel. (+39) 0376/534 561 - fax (+39) 0376/536 393 - www.piusi.com